



# La MARCHE®

La Marche Manufacturing Company

www.lamarchemfg.com

## A36D Series

Controlled Ferroresonant Rectifier /  
Power Supply with Data Logging

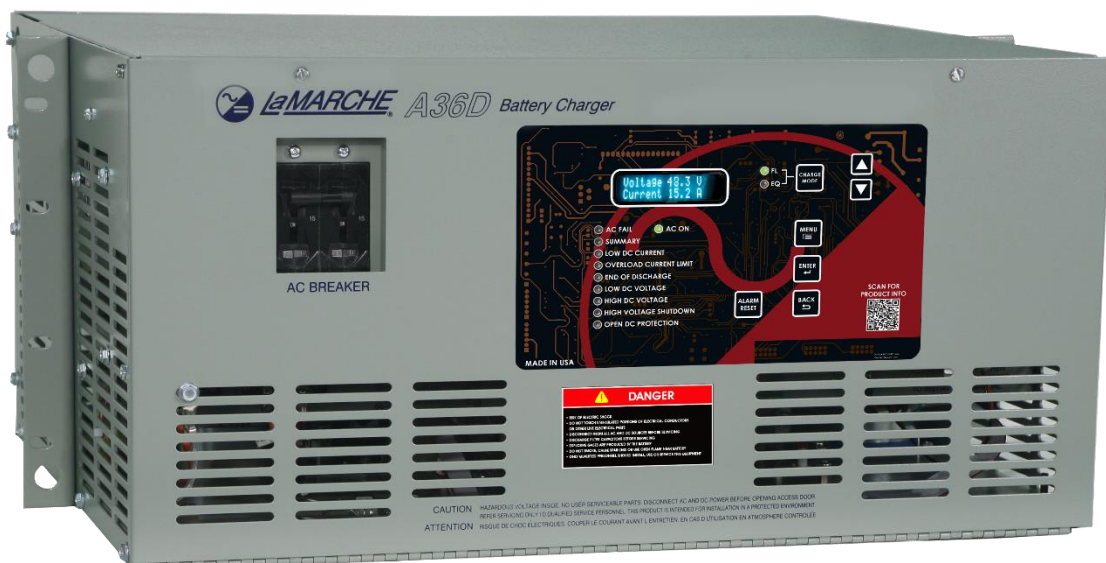

## Installation and Operation Manual

## Important Safety Instructions

Before using this equipment, read all manuals and other documents related to this charger and other equipment connected to this charger. Always have a copy of a charger's manual on file nearby in a safe place; if a replacement copy of a manual is needed, it can be found at [www.lamarchemfg.com](http://www.lamarchemfg.com).

### Electrical Safety



**WARNING:** Hazardous Voltages are present at the input of power systems. The output from chargers and from batteries may be low in voltage, but can have a very high current capacity that may cause severe or even fatal injury.

When working with any live battery or power system, follow these precautions:

- Never work alone on any live power system; someone should always be close enough to come to your aid.
- Remove personal metal items such as rings, bracelets, necklaces, and watches.
- Wear complete eye protection (with side shields) and clothing protection.
- Always wear gloves and use insulated hand tools.



**WARNING:** Lethal Voltages are present within the power system. Parts inside the charger may still be energized even when the charger has been disconnected from the AC input power. Check with a meter before proceeding. Do not touch any uninsulated parts.

- A licensed electrician should be used in the installation of any charger.
- Always disconnect the charger from the supply, batteries, and loads before performing maintenance, replacing parts, or cleaning.
- Always assume that an electrical connection is live and check the connection relative to ground.
- Be sure that neither liquids nor any wet material come in contact with any internal components.
- Do not operate this charger outside the input and output ratings listed on the charger nameplate.
- Do not use this charger for any purpose not described in the operation manual.

### Mechanical Safety

- This charger or parts of the charger may get very hot during normal operation, use care when working nearby.
- Do not expose equipment to rain or snow. Always install in a clean, dry location.
- Do not operate equipment if it has received a sharp blow, been dropped, or otherwise damaged in any way.
- Do not disassemble this charger. Incorrect re-assembly may result in a risk of electric shock or fire.

### Battery Safety



**WARNING:** Follow all of the battery manufacturer's safety recommendations when working with or around battery systems. DO NOT smoke or introduce a spark or open flame in the vicinity of a battery. Some batteries generate explosive gases during normal battery operation.

- To reduce risk of arc, connect and disconnect the battery only when the charger is off.
- If it is necessary to remove battery connections, always remove the grounded terminal from the battery first.
- Remove personal metal items such as rings, bracelets, necklaces, and watches.
- Always wear rubber gloves, safety glasses, and a rubber lined vest/apron when working near a battery.
- Have plenty of fresh water and soap nearby in enclosure the battery electrolyte contacts skin, clothing, or eyes.
- If the battery electrolyte contacts skin or clothing, wash immediately with soap and water.
- If the electrolyte enters the eye, immediately flood the eye with running cold water for at least ten (10) minutes and seek medical attention immediately.
- Do not drop or place any materials on a battery. A spark or short-circuit could cause an explosion.

## Charger Location

- Allow at least 6 inches of free air on all vented surfaces for proper cooling
- Allow sufficient clearance to open the front panel for servicing.
- Do not operate this charger in a closed-in area or restrict ventilation in any way.
- Do not place charger below battery.
- Never allow battery electrolyte to drip on this charger when reading the specific gravity or filling the battery.
- Never place this charger directly above a standard flooded battery. Gases from the battery will corrode and damage equipment.
- A sealed maintenance free or valve regulated lead acid (VRLA) battery may be placed below this equipment.

## Check for Damages

Prior to unpacking the product, note any damage to the shipping container and take pictures. Unpack the product and inspect the exterior and interior of product for damage. If any damage is observed, take pictures and contact the carrier immediately to file a damage claim. Contact La Marche for a Return Material Authorization number to have the charger sent back for evaluation and repair.



**CAUTION:** Failure to properly file a claim for shipping damages, or provide a copy of the claim to La Marche, may void warranty service for any physical damages reported for repair.

## Returns for Service

Save the original shipping container. If the product needs to be returned for service, it should be packaged in its original shipping container. If the original container is damaged/unavailable, make sure the product is packed with at least three inches of shock-absorbing material to prevent shipping damage. *La Marche is not responsible for damage caused by improper packaging of returned products.*

## Inspection Checklist

- Enclosure exterior and interior is not marred or dented.
- There are no visibly damaged components.
- All internal components are secure.
- Printed circuit boards are firmly seated.
- All hardware and connections are tight.
- All wire terminations are secure.
- All items on packing list have been included.

## Handling

Equipment can be very heavy with uneven distribution of weight. Use adequate manpower or equipment for handling. Until the equipment is securely mounted, care must be used to prevent equipment from being accidentally tipped over or dropped.

## Table of Contents

Important Safety Instructions .....	i
Table of Contents .....	iii
Model Scope/General Description .....	1
Understanding the Model Number .....	1
Optional Accessories Included in the Charger .....	1
Quick Start Guide.....	2
1 Equipment Handling .....	3
1.1 Storing the A36D .....	3
1.2 Moving the A36D .....	3
2 Installation .....	5
2.1 Mounting the A36D .....	5
2.1.1 Rack-Mounting the A36D .....	6
2.1.2 Floor-Mounting the A36D .....	6
2.2 AC Input Connections .....	8
2.3 DC Output Connections .....	9
2.3.1 Paralleling Connections .....	10
2.4 Alarm Connections .....	10
2.4.1 Alarm Connection Procedure .....	12
2.4.2 Understanding the Alarms.....	12
2.5 External Temperature Compensation (Option 11W/11Y).....	14
2.6 Load Sharing .....	15
2.7 Remote Equalize .....	16
2.8 Remote Voltage Sensing.....	17
2.9 DNP 3.0 / Modbus SCADA Interface (Option 21P/21Q) .....	17
2.10 Battery Side Alarm Sensing (Option 565) .....	17
3 Operation .....	18
3.1 Starting the A36D .....	18
3.2 Digital Control Board .....	19
3.3 Selecting the Charging Mode .....	20
3.3.1 Equalize Timer Modes.....	20
3.4 Output Voltage Adjustments .....	21
4 Controller Menus.....	22
4.1 Settings Menu.....	22
4.1.1 Float/EQ Voltage/Current Limit.....	22
4.1.2 Alarm Settings.....	23
4.1.3 Advanced Settings .....	23
4.1.4 Return to Defaults .....	28
4.2 Test Menu .....	28

4.2.1	Test LEDs .....	28
4.2.2	Test Relays .....	28
4.3	Reset All Alarms .....	29
4.4	Last 10 Events .....	29
5	Data Logging .....	29
5.1	Events Only Logging.....	30
5.2	Interval Logging.....	30
5.3	Formatting the MicroSD Card .....	31
5.4	Installing/Removing the MicroSD Card.....	32
5.5	Reading the Log File.....	32
6	Frequently Asked Questions.....	33
7	Service .....	34
7.1	Performing Routine Maintenance.....	34
7.2	Troubleshooting Procedure .....	35
7.3	Troubleshooting Chart.....	36
7.3.1	Ground and Short Circuit Test. ....	37
7.3.2	Troubleshooting the TRIAC .....	37
7.3.3	Troubleshooting and Replacing Power Silicon Diodes/Modules.....	38
7.3.4	Checking Capacitors .....	38
Appendix A:	A36D Specifications.....	39
Appendix B:	A36D Menu Structure Flowchart.....	40
Appendix C:	MicroSD Card File Retrieval Instructions .....	40
Appendix D:	A36D Current Draw and Feeder Breaker Sizes (Single Phase) .....	42
Appendix E:	A36D Current Draw and Feeder Breaker Sizes (Three Phase).....	43
Appendix F:	A36D Heat Losses .....	44
Appendix G:	Document Control and Revision History.....	455

## Model Scope/General Description

The La Marche Model A36D Controlled Ferroresonant Rectifier/ Power Supply has many inherent advantages such as voltage regulation, high efficiency, high power factor and short circuit protection. These chargers provide adjustable voltage levels for floating or equalizing lead or nickel-cadmium cells, which can be done digitally through the LCD display. The equalize cycle is activated either manually through a button on the front panel, or automatically scheduled. (adjustable through the menu).

Steady state output voltage remains within  $\pm 0.5\%$  of the setting from no load to full load and for AC input voltages within  $\pm 10\%$  of the nominal input voltage. The model A36D is internally filtered to be no greater than 32dBm ("C" message weighting) and 30 millivolts RMS for all conditions on input voltage and output load with or without batteries connected. This allows the A36D to be used as a battery eliminator.

## Understanding the Model Number

The A36D model number is coded to describe the options that are included. Find the model number on the nomenclature nameplate of the charger. Then follow the chart to determine the configuration of your battery charger.

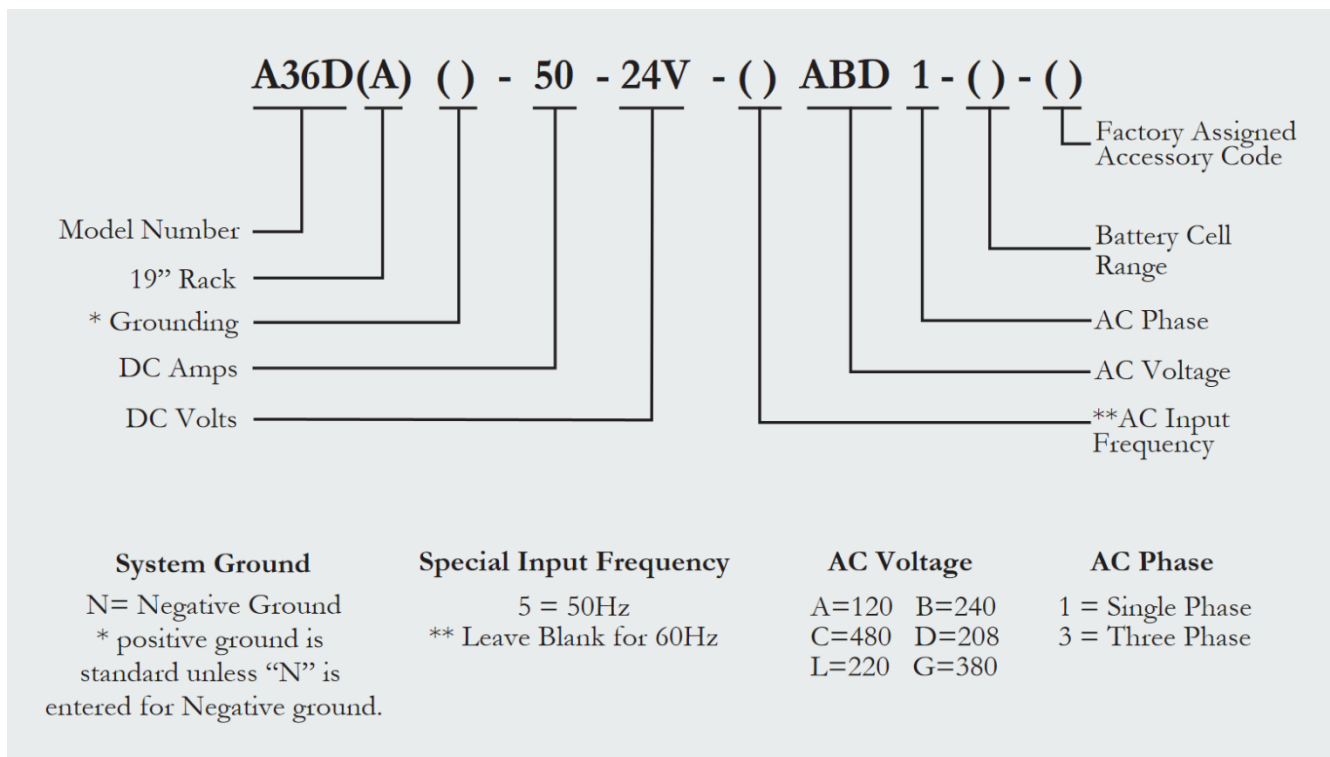

## Optional Accessories Included in the Charger

This charger may have been outfitted with a number of optional accessories or option packages. To determine the options included (if any) refer to the cover page of the manual package. If the manual package that is included with the charger is no longer available, contact La Marche and provide the model or serial number of the charger to receive a list of the included accessories.

### La Marche A36D Battery Charger: Getting Started

**WARNING: Please read the Important Safety Instructions before proceeding. Make sure to check for any shipping damages before getting started.**

#### 1 – Connect Proper AC Voltage

Confirm proper AC voltage against charger nameplate. If charger is multi-tap, refer to AC Input Voltage Tap Configuration table inside the charger or on charger schematic. Close AC breaker.

#### 2 – Adjust Charger DC Output & Alarms

To access the Settings Menu, press the MENU button, select “Settings Menu,” and press the ENTER button. Once in the Settings Menu, the user can navigate the menus with the up and down arrows. To enter a submenu, use the ENTER button. The BACK button returns to the previous menu. When making a selection, the ENTER button will store the value and step back. The BACK button will not save the change and will go a step back. At any point, the settings menu can be exited, with or without saving the settings.

##### Float, Equalize Voltage, & Current Limit

- Float Voltage
- Equalize Voltage
- Current Limit

##### Alarm Settings

- Alarm Thresholds
  - Low Current
  - Overload
  - Low Voltage
  - End of Discharge
  - High Voltage
  - High Voltage Shutdown
- Summary Alarm Selects
  - AC Fail in Summary
  - Low Current in Summary

##### Advanced Settings

- Equalize Timer Settings
  - Equalize Timer Mode
  - Equalize Timer Hours
- Advanced Alarm Settings
  - Alarm Delays
  - Alarm Operation/Alarm Latching
- Temperature Compensation
  - Temperature Compensation Enable
  - Temperature Compensation Rate
- Communication Settings (if applicable)
  - Refer to manual for setup
- LCD Settings
  - Auto Off 2 Minutes or Always On
- Clock Settings (Date & Time)
- Logging and Files (Log Interval)

#### 3 – Connect Batteries & Loads

Observe proper polarity when making battery and load connections. Close DC breaker, if applicable.

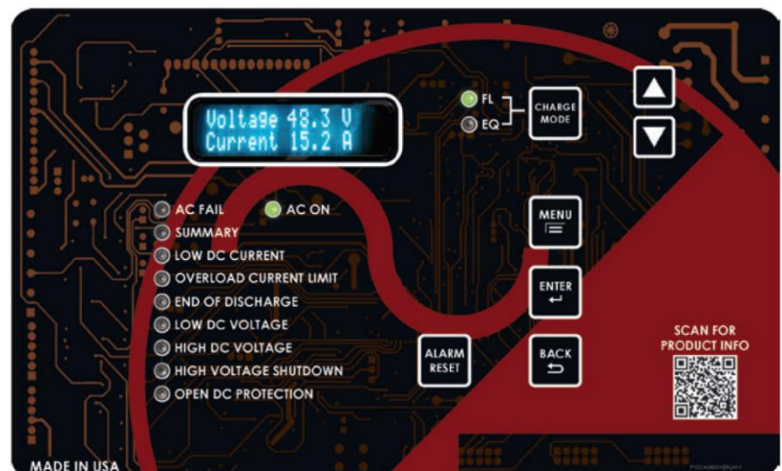

# 1 Equipment Handling

## 1.1 Storing the A36D

If the A36D is to be stored for more than a few days after delivery, it should be stored within its shipping container. The location chosen for storage should be within an ambient temperature of -40 to 185° F (-40 to 85° C) with a non-condensing relative humidity of 0 to 95%. Storage should not exceed 2 years due to the limited shelf life of the DC filter capacitors when they are not in service.

## 1.2 Moving the A36D

After careful inspection and upon verification that the A36D is undamaged, identify the enclosure style and weight of the A36D charger. Refer to the tables below.

Output Voltage	Frequency	Ampere Rating						
		10 ADC	12 ADC	15 ADC	20 ADC	25 ADC	30 ADC	50 ADC
12 VDC	60 Hz			39 Case 45 lbs 20.4 kg	39 Case 50 lbs 22.7 kg	39 Case 54 lbs 24.5 kg	33 Case 78 lbs 35.4 kg	33 Case 99 lbs 44.9 kg
	50 Hz							33 Case 109 lbs 49.4 kg
24 VDC	60 Hz	39 Case 50 lbs 22.7 kg	39 Case 54 lbs 24.5 kg	39 Case 58 lbs 26.3 kg	39 Case 64 lbs 29 kg	33 Case 99 lbs 44.9 kg	33 Case 115 lbs 52.2 kg	33 Case 130 lbs 59 kg
	50 Hz					33 Case 109 lbs 49.4 kg	33 Case 127 lbs 57.6 kg	33 Case 143 lbs 64.9 kg
48 VDC	60 Hz	39 Case 64 lbs 29 kg	39 Case 70 lbs 31.8 kg	33 Case 110 lbs 49.9 kg	33 Case 118 lbs 53.5 kg	33 Case 125 lbs 56.7 kg	33 Case 133 lbs 60.3 kg	33 Case 180 lbs 81.6 kg
	50 Hz				33 Case 130 lbs 59 kg	33 Case 138 lbs 62.6 kg	33 Case 147 lbs 66.7 kg	33 Case 198 lbs 89.8 kg

**Table 1** - Case Type and Weight (10-50 ADC)



Output Voltage	Frequency	Ampere Rating						
		75 ADC	100 ADC	150 ADC	200 ADC	200 ADC	300 ADC	400 ADC
12 VDC	60 Hz	33E Case 110 lbs 49.9 kg	33E Case 130 lbs 59 kg	9D Case 145 lbs 65.8 kg	9D Case 180 lbs 81.6 kg			
	50 Hz	33 Case 121 lbs 54.9 kg	4D Case 143 lbs 64.9 kg	9D Case 160 lbs 72.6 kg	9D Case 198 lbs 89.8 kg			
24 VDC	60 Hz	33E Case 145 lbs 65.8 kg	33E Case 180 lbs 81.6 kg	9D Case 280 lbs 127 kg	9D Case 310 lbs 140.6 kg	43 Case 600 lbs 272.2 kg	43 Case 700 lbs 317.5 kg	43 Case 800 lbs 362.9 kg
	50 Hz	33E Case 160 lbs 72.6 kg	33E Case 198 lbs 89.8 kg	9D Case 309 lbs 140.2 kg	9E Case 342 lbs 155.1 kg	43 Case 661 lbs 299.8 kg	43 Case 771 lbs 349.7 kg	44 Case 881 lbs 399.6 kg
48 VDC	60 Hz	9D Case 260 lbs 117.9 kg	9D Case 286 lbs 129.7 kg	72 Case 528 lbs 239.5 kg	72 Case 572 lbs 259.5 kg	43 Case 755 lbs 342.5 kg	44 Case 900 lbs 408.2 kg	44 Case 1193 lbs 541.1 kg
	50 Hz	9D Case 287 lbs 130.2 kg	9E Case 315 lbs 142.9 kg	72 Case 582 lbs 264 kg	72 Case 630 lbs 285.8 kg	43 Case 832 lbs 377.4 kg	44 Case 992 lbs 450 kg	44 Case 1315 lbs 596.5 kg

**Table 2 - Case Type and Weight (75-400 ADC)**

Output Voltage	Frequency	Ampere Rating					
		15 ADC	20 ADC	25 ADC	30 ADC	50 ADC	75 ADC
12 VDC	60 Hz				4D Case 78 lbs 35.4 kg	4D Case 99 lbs 44.9 kg	4D Case 110 lbs 49.9 kg
24 VDC	60 Hz			4D Case 99 lbs 44.9 kg	4D Case 115 lbs 52.2 kg	4D Case 130 lbs 59 kg	4D Case 145 lbs 65.8 kg
48 VDC	60 Hz	4D Case 110 lbs 49.9 kg	4D Case 118 lbs 53.5 kg	4D Case 125 lbs 56.7 kg	4D Case 133 lbs 60.3 kg	4D Case 180 lbs 81.6 kg	

**Table 3 - Case Type and Weight (19" Rack Mount Case)**

## 2 Installation

### 2.1 Mounting the A36D

When mounting the A36D in any configuration, consider the size and weight of the charger. The wall, rack, and/or floor must be able to support the weight of the charger as well as an additional safety factor. Verify the weight of the A36D charger using Tables 1, 2 and 3, and the method of mounting using Table 4 below. The location chosen for the charger should have the following considerations:

- Location should be within an ambient temperature range of 32 to 122°F (0 to 50°C) with a non-condensing relative humidity no higher than 95%.
- The A36D should be mounted in an area free of explosive materials and away from drips and splatter.
- The A36D utilizes convection cooling, so a clearance of at least 6in (152mm) of free air must be maintained on vented sides.
- Maintain 36in (914mm) or more of clearance at the front of the charger in order to allow for operation and maintenance.
- The bolts or screws used to secure the charger should be sufficient length to assure a vibration-free mounting.
- The preferred fastener is a machine bolt backed with a flat washer, lock washer, and nut. All hardware should be corrosion-resistant.

Enclosure Number	Cable Entry (when facing unit)		Standard Mounting	Optional Mounting Kits
	AC Input	DC Output		
<b>4D</b>	Left Top / Back	Right Top / Back	19/23" Rack	Wall* / Floor**
<b>39</b>	Left Top / Back	Right Top / Back	19/23" Rack	Wall* / Floor**
<b>9E</b>	Left Top / Back	Right Top / Back	23" Rack	Wall* / Floor**
<b>33</b>	Left Top / Back	Right Top / Back	23" Rack	Wall* / Floor**
<b>33E</b>	Left Top / Back	Right Top / Back	23" Rack	Wall* / Floor**
<b>43</b>	Top Left	Top Back	Floor	X
<b>44</b>	Top Left	Top Back	Floor	X
<b>72</b>	Right/Bottom/Side	Bottom	Floor	X

\* Wall mounting brackets required and overall height would change. Case size may differ depending on optional accessories.

\*\* Floor mounting brackets required and overall height would change. Case size may differ depending on optional accessories.

**Table 4 - Available Mounting Methods**

### 2.1.1 Rack-Mounting the A36D

The A36D can be installed in most relay racks with standard EIA hole spacing. If a relay rack is needed, they are available for purchase from La Marche. The **4D**, **9E**, **33**, **33E**, and **39** enclosures are shipped from the factory with the necessary brackets installed for rear mounting on a relay rack. The rack mounting bracket for the **4D** and **39** enclosures allow for mounting on a 19" or 23" rack, and the **9E**, **33**, and **33E** enclosures allow for mounting on a 23" rack.

#### Rack Mounting Procedure

Before installing the charger on the rack, locate the conduit entrances and assure the knockouts on the top, sides, or bottom of the charger are accessible after the charger is rack-mounted. To rack mount the A36D, first mount the charger onto the rack-mounting brackets using the hardware supplied. Second, install the brackets onto the rack. Provide at minimum 6in (152mm) of air space above and below to allow for cooling.

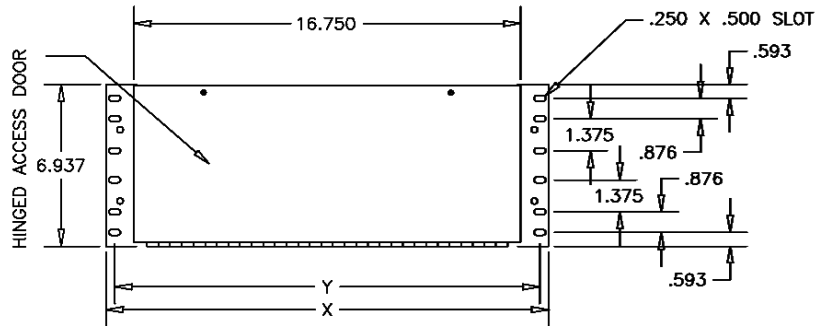

Figure 1 - 39 Enclosure Bolt Pattern

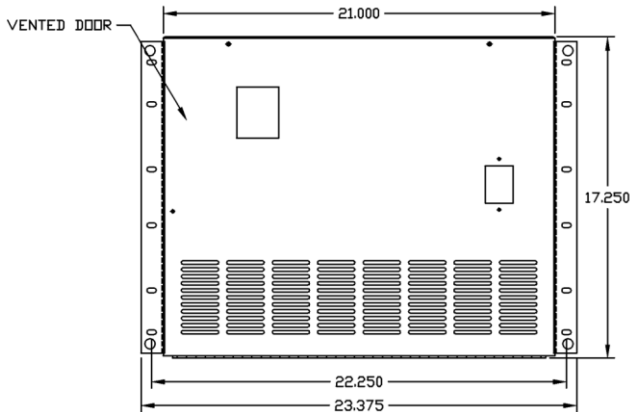

Figure 2 - 9E Enclosure Bolt Pattern

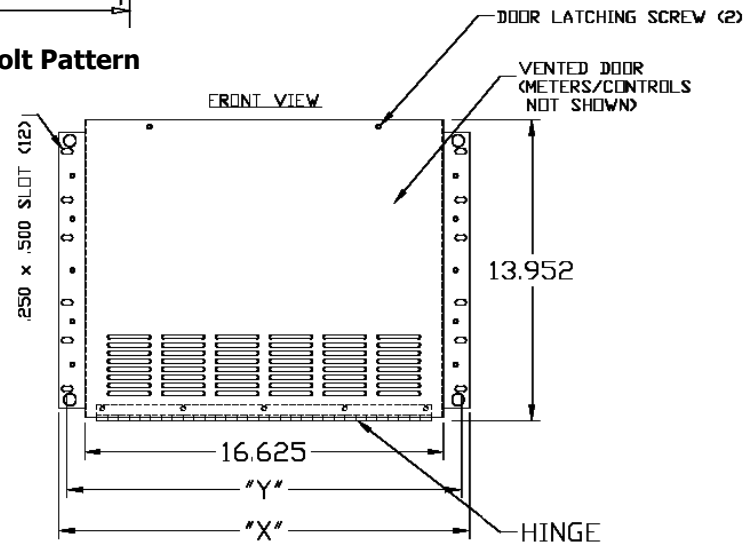

Figure 3 - 4D Enclosure Bolt Pattern

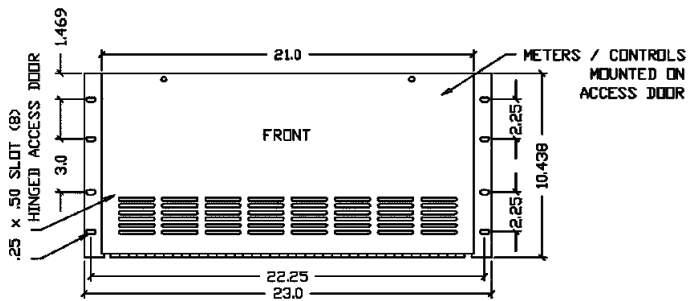

Figure 4 - 33E Enclosure Bolt Pattern

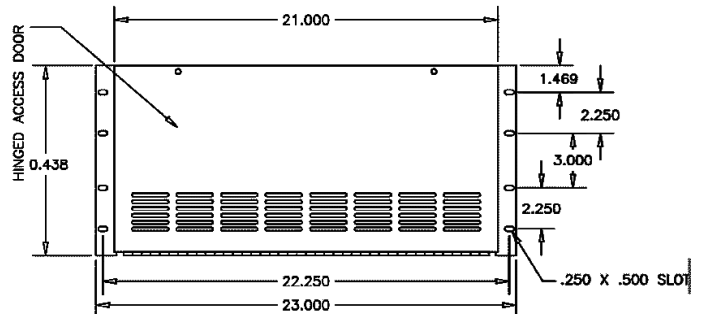
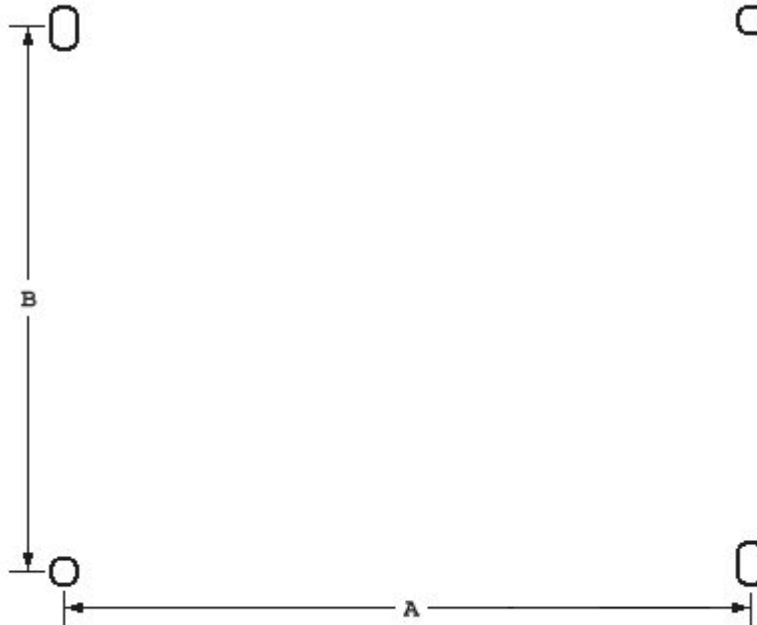

Figure 5 - 33 Enclosure Bolt Pattern

**NOTE:** All dimensions are in inches. For further A36D enclosure information, see the outline drawings online at <http://www.lamarchemfg.com/info/enclosure-drawings.html>

### 2.1.2 Floor-Mounting the A36D

Floor-mounting the **43, 44, and 72** enclosures is standard. To floor-mount the A36D, install four to six anchor bolts into the floor. Place the charger on the bolts, add appropriate mounting hardware, and tighten securely. The figure below shows the footprint and the bolt size of each A36D enclosure style. All dimensions are in inches.



Case Size	A	B	Bolt Size
<b>43</b>	11.5"	12"	3/8"
<b>44</b>	22"	17.06	3/8"
<b>72</b>	25.75"	17.5"	1/4"

**Figure 6 - A36D Enclosure Footprint**

## 2.2 AC Input Connections

Before beginning any work inside the charger, ensure that all incoming AC supply power is off at the main breaker box and the charger’s breakers are off. Check that the source voltage and frequency match the voltage and frequency listed on the charger nameplate. For chargers with transformer taps, verify that the tap has been set to the correct AC input and refer to charger schematic for input tap settings. Select wire size using the table below. This is based on an overload current of 110-115% of the input current listed on the charger nameplate.

**NOTE:** Feeder breaker should be sized to match the size of the AC protection used in charger.

Breaker Size/ Fuse Size - Amps	AWG Minimum Wire Size Requirement for User Connection	AWG Minimum Ground Wire Size
3	#14	#14
5	#14	#14
10	#14	#14
15	#14	#14
20	#12	#12
25	#10	#12
30	#10	#10
40	#8	#10
50	#8	#10
60	#6	#10
70	#6	#8
80	#4	#8
90	#4	#8
100	#4	#8
125	#2	#6
150	#1	#6
175	#1/0	#6
200	#2/0	#6
250	#4/0	#4
300	250 MCM	#4
400	400 MCM	#2
500	600 MCM	#2

**Table 5 – AC/DC & Ground Wire Size Minimum Requirements**

**(All wires specified in the table are rated at 90 °C or 194 °F)**

**NOTE:** These are recommended sizes per La Marche Standards. The National Electrical Code (NEC) and Local Wiring Codes must be followed.

### AC Connection Procedure

First, connect an adequate earth ground lead (use table above for sizing) to the terminal marked ground. Install the input AC cables to the AC input terminals of the charger.

### 2.3 DC Output Connections

Before making any of DC output connections, make sure you have read and fully understand the DC Connection Procedure below. Select proper size for the DC wiring from the wire size table on the previous page. If the distance between the charger’s DC output and the DC load exceeds 10 feet, use the Power Cable Guide below to minimize the voltage drop across the wire distance.

**NOTE:** It is recommended to use a battery disconnect breaker between charger and battery bank; helpful during battery or charger maintenance.

### Power Cabling Guide

Use the following formulas and table to determine proper wire size for minimal voltage drop.

#### Table of Conventions

- CMA = Cross section of wire in circular MIL area
- A = Ultimate drain in amperes
- LF = Conductor loop feet
- MaxAmp = Maximum allowable amps for given voltage drop
- AVD = Allowable voltage drop
- K = 11.1 for commercial (TW) copper wire (KS5482-01)  
= 17.4 for aluminum (KS20189)

#### Calculating Wire Size Requirements

$$CMA = \frac{A \times LF \times K}{AVD}$$

#### Calculating Current Carrying Capacity of Wire

$$MaxAmp = \frac{CMA \times AVD}{LF \times K}$$

SIZE (AWG)	AREA CIR.MILS	SIZE (MCM)	AREA CIR.MILS
18	1620	250	250000
16	2580	300	300000
14	4110	350	350000
12	6530	400	400000
10	10380	500	500000
8	16510	600	600000
6	26240	700	700000
4	41740	750	750000
3	52620	800	800000
2	66360	900	900000
1	83690	1000	1000000
0	105600	1250	1250000
00	133100	1500	1500000
000	167800	1750	1750000
0000	211600	2000	2000000

**Table 6 – Wire Size/Area Table**

### DC Connection Procedure

To prevent the DC circuit breaker from tripping when connecting the battery, connections should be done in the following order.

1. Make sure that the incoming voltage to the charger is turned off.
2. Turn off/open the charger’s AC and DC circuit breakers.
3. Connect the battery cables to the charger’s DC output terminals. ***OBSERVE PROPER POLARITY.***
4. Energize the charger by supplying AC voltage and turning on/closing the charger’s AC breaker. This will charge the capacitors inside the charger and eliminate heavy arcing when the battery is connected.
5. After 30 seconds, turn on/close the DC breaker.

### 2.3.1 Paralleling Connections

A36D battery chargers have the capability to be installed in parallel for redundant applications. Take into consideration, the chargers being setup for paralleling MUST be of the same DC output rating and should all be either A36D model chargers with the same front panel display board. Please confirm each charger model on the nameplate on front prior to making connections. Please follow the steps below:

1. Power up the chargers prior to making any connections to the DC output.
2. Adjust the Float and Equalize output voltages of each individual charger to same desired level.
3. Turn off all chargers.
4. Connect the DC output of all chargers in parallel to the same DC load/battery, refer to figure below.
5. Turn on all chargers.

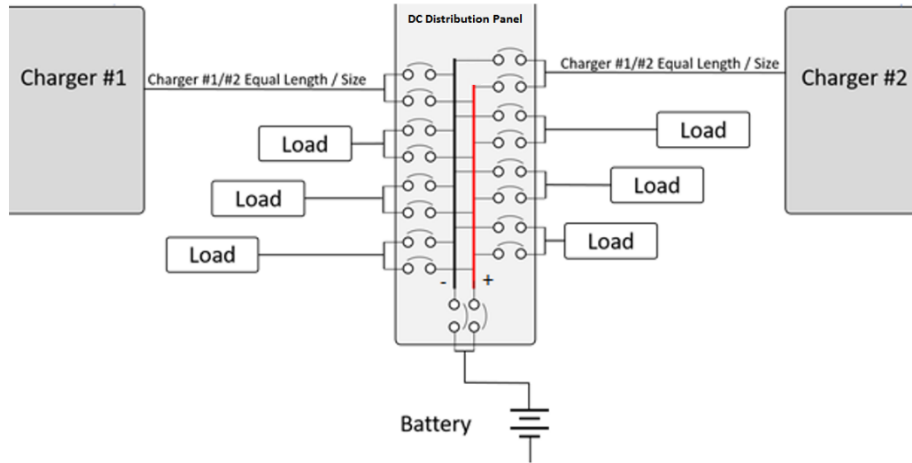
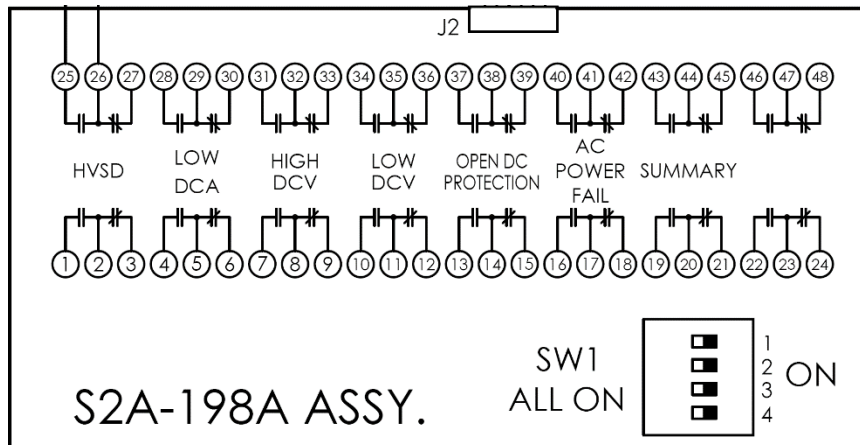

**Figure 8 – Example Paralleling Diagram**

**NOTE:** Paralleling is not to be confused with load sharing. If load sharing is desired, please refer to Section 2.7.

### 2.4 Alarm Connections

Seven alarm relays (and 9 alarm LEDs) are included as a standard feature of the A36D. The included alarms are Low DC Current, Low DC Voltage, High DC Voltage, High Voltage Shutdown, AC Failure, Open DC Protection, and Summary alarm. Each alarm includes two sets of form 'C' contacts, enabling the user to connect multiple remote annunciators. Refer to the figure below for alarm contact connections.



**Figure 7 – User Connections to Alarm Contacts on S2A-198 Board**

Alarm LEDs are provided for the following alarms: AC Fail, Low DC Voltage, End of Discharge, High DC Voltage, High Voltage Shutdown, Low DC Current, Overload/Current Limit, Open DC Protection, and Summary. Refer to the figure below.

If an alarm condition occurs for a default time of longer than 5 seconds, the Summary alarm relay will activate if the corresponding alarm is included in the Summary alarm. The HVSD alarm is default set to trigger after 20 seconds. When an alarm activates, the specific indicator on the front panel will light, any connected remote annunciators will activate, and the display will cycle through all active alarms.

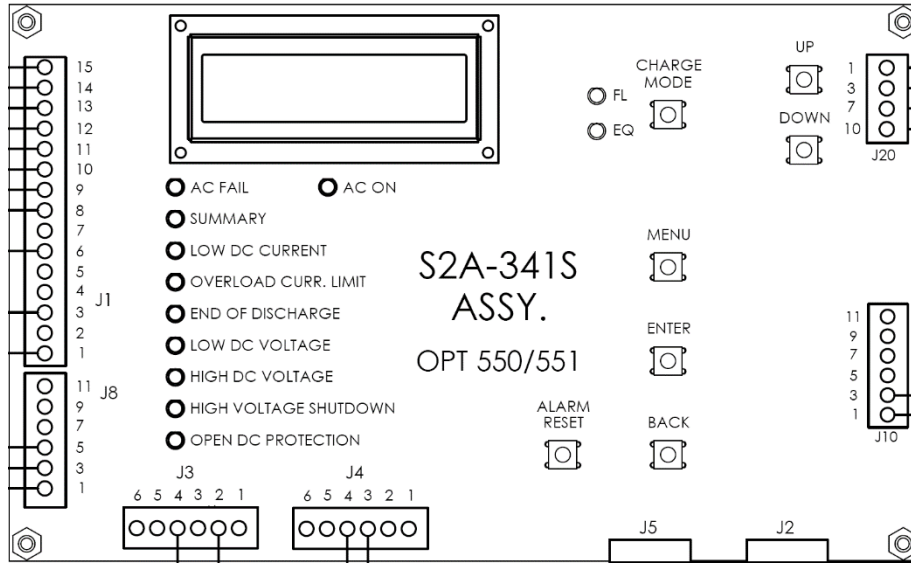

**Figure 8 – S2A-341S Display/Control Board**

All alarm contacts for the S2A-198 relay board are designed to be fail-safe. In other words, if both the AC and DC power are removed, each alarm will be indicating in its correct state. To accomplish this, certain alarm relays are de-energized on failure (such as Low DC Current), and certain alarm relays are energized on failure (such as High DC Voltage). Refer to Table 7 for the logic of each alarm and refer to Table 8 for alarm contact specifications.

S2A-198 Relay Information	
Relay Function	Logic
AC Power Fail	De-Energize on Fail
Summary	De-Energize on Fail
High DC Voltage Shutdown	Energize on Fail
Low DC Current	De-Energize on Fail
High DC Voltage	Energize on Fail
Low DC Voltage	De-Energize on Fail
Open DC Protection	De-Energize on Fail

**Table 7 – Alarms Relay Logic**

	Load	Resistive Load (P.F. = 1)
<b>Contact Material</b>		Ag (Au clad)
<b>Maximum Allowed Current</b>		2 A
<b>Max. Operating Voltage and Current</b>		0.5 A at 125 VAC
		0.6 A at 110 VDC
		2.0 A at 30 VDC
<b>Max. Switching Capacity</b>		62.5 VA
		60 W
<b>Min. Permissible Load</b>		10 $\mu$ A / 10 mVDC

**Table 8 – Alarm Contact Specifications**



### 2.4.1 Alarm Connection Procedure

Before making any connections to the A36D, ensure that the AC power is off at the main breaker box and the charger's breakers are off. Verify that no voltage is present by using a voltmeter at all input and output terminals.

For relays mentioned as ENERGIZED on alarm condition:

If it is desired that the annunciator be active until the alarm triggers, connect the annunciator leads to the **NC** and **C** contacts of the desired alarm (located on the relay alarm contacts on S2A-198 board). If it is desired that the annunciator be deactivated until the alarm triggers, connect the annunciator leads to the **NO** and **C** contacts of the desired alarm.

For relays mentioned as DE-ENERGIZED on alarm condition:

If it is desired that the annunciator be active until the alarm triggers, connect the annunciator leads to the **NO** and **C** contacts of the desired alarm (located on the relay alarm contacts on S2A-198 board). If it is desired that the annunciator be deactivated until the alarm triggers, connect the annunciator leads to the **NC** and **C** contacts of the desired alarm.

**EXAMPLE:** The user wants a green lamp to be illuminated at all times and wants a red lamp to illuminate and a speaker to sound when the Summary alarm triggers. The user would make the connections to the **NC** and **C** contacts on one set of the Summary relay contacts between the speaker and a power supply. On the other set of Summary relay contacts, the customer would connect the **NO** and **C** contacts between the green lamp and power supply, and would connect the **NC** and **C** contacts between the red lamp and power supply. Refer to Figure 9.

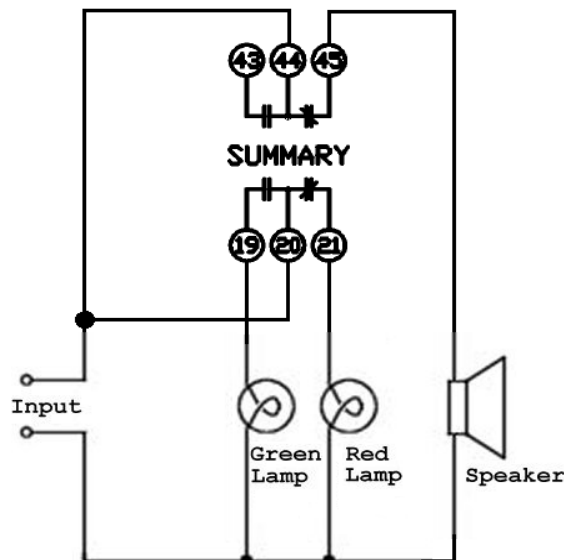

**Figure 9 – Example Connections**  
(User Provided Equipment)

## 2.4.2 Understanding the Alarms

**HIGH VOLTAGE SHUTDOWN ALARM** will trigger and the red "HIGH VOLTAGE SHUTDOWN" LED will turn on if the output DC voltage of the charger rises above the alarm threshold for longer than 20 seconds and there is load on the charger. This is usually due to the failure of an internal charger component, but could also be the result of maladjustments of the output voltage settings. If the High DC Voltage Shut Down alarm activates, the DC output of the charger is shut off by tripping the AC breaker to prevent irreversible damage to the battery. To reset, press the ALARM RESET button on the front panel, then close the AC breaker.

**NOTE:** *The HVSD alarm will not trigger if there is a Low Current alarm present.*

**HIGH DC VOLTAGE ALARM** will trigger and the red "HIGH DC VOLTAGE" LED will turn on if the output DC voltage rises above the specified voltage threshold of the alarm for longer than 5 seconds. This is usually caused by maladjustments of the output voltage settings, or in rare cases, by a failure of an internal charger component.

**LOW DC VOLTAGE ALARM** will trigger and the red "LOW DC VOLTAGE" LED will turn on if the DC voltage falls below the specified voltage threshold of the alarm for longer than 5 seconds. This is usually due to an AC Failure, or the charger is overloaded into deep-current limit. It could also be caused by maladjustments of the output voltage settings, or in rare cases, by a failure of an internal charger component.

**OPEN DC PROTECTION ALARM** will trigger and the red "OPEN DC PROTECTION" LED will turn on if the output DC breaker/fuse has been opened. In the case the DC protection is opened, the bottom line of the display will read "OPEN DC PROT".

**AC POWER FAIL ALARM** will trigger, the green "AC ON" LED will turn off, and the red "AC FAIL" LED will turn on when the AC power to the charger is lost. The alarm will automatically reset when AC power is restored to the charger. When AC power is lost the front panel display and indicators will remain powered by the connected batteries.

**SD CARD REMOVED ALARM** is triggered when a microSD card is not detected on the microSD card slot.

**SUMMARY ALARM** is triggered and the "SUMMARY" LED will turn on when any of the following alarms are activated:

- Low DC Voltage
- High DC Voltage
- S2A-407S Failure\*\*
- Open DC Protection
- Overload/Current Limit
- AC Failure\*
- Low DC Current\*

*\* Optional to include in Summary Alarm*

*\*\* Applicable if respective option is included*

**LOW DC CURRENT ALARM** will trigger and the amber "LOW DC CURRENT" LED will turn on if the output DC current of the charger falls below the alarm threshold for longer than 5 seconds. This is usually caused by the load (if applicable) being disconnected or going into a sleep state as well as the battery (if applicable) reaching a full charge. This could also be the result of maladjustments of the output voltage settings. In rare cases, this could be the result of certain load sharing setups in which the other charger is set up to supply more power to the load. This alarm can be disabled if considered a nuisance alarm.

**OVERLOAD/CURRENT LIMIT ALARM** share one LED. The "Overload/Current Limit" alarm LED will flash when the charger is in current limit, i.e. regulating the load in a constant current mode. When the charger is overloaded, the "Overload/Current Limit" LED will turn on solid. An overload requires two simultaneous conditions; the charger must be in current limit and the voltage has depressed to below the End of Discharge alarm percentage or threshold; typical: 1.75V/C LA, 1.1V/C NC.

Most alarms have adjustable time delays to energize; ranging from 0 through 255 seconds. Refer to Table 10 for the factory setting of each alarm.

**NOTE:** *All alarms automatically reset when the alarm condition is corrected, except the High Voltage Shutdown alarm. Refer to the corresponding alarm description above for reset instructions.*

## 2.5 External Temperature Compensation (Option 11W/11Y)

The natural voltage of a battery changes as a function of temperature change. As the battery temperature rises, the effective voltage of the battery decreases. Without Temperature Compensation, the battery charger will always produce a set constant output voltage. As the battery temperature increases, this constant voltage will then induce a higher output current from the charger. This higher current can result in overcharging the battery, which in turn can result in damage to the batteries.

The A36D temperature compensation rate can easily be adjusted in the menu from the default setting OFF to 1mV/°C/cell, up to 5mV/°C/cell. The temperature compensation considers 25°C as the nominal ambient temperature and adjusts the voltage level based on the difference between the actual temperature and 25°C. The battery manufacturer should be consulted for the proper temperature compensation slope, as well as the Float and Equalize voltage set points.

An internal temperature probe is standard and will compensate for overall ambient temperature changes if the batteries and charger are in the same room. The accuracy of temperature compensated charging can be greatly enhanced by using an optional remote temperature probe directly on the battery (Option 11W/11Y). Option 11W includes a 24-foot long temperature probe and Option 11Y includes a 100-foot long temperature probe. With either option, approximately two feet of the probe is taken inside the charger enclosure.

### External Temperature Probe Connection Procedure

Before making any connections to the A36D, ensure that the AC power is off at the main breaker box and the charger's breakers are off. Verify that no voltage is present by using a voltmeter at all input and output terminals.

**NOTE:** Procedure only applies on A36D chargers with Option 11W/11Y.

#### Procedure for Chargers with S2A-255 Board:

1. Locate the **TS-6** terminal strip inside the charger.
2. Connect wire marked **F** to terminal **1** and wire marked **G** to terminal **2**. Refer to Figure 10.
3. Connect the black lead of the external probe to the other end of terminal **1**, and the red lead to the other end of terminal **2**.
4. Place the external probe in a desired location.  
(It is recommended that the battery manufacturer be consulted for placement of the probe)

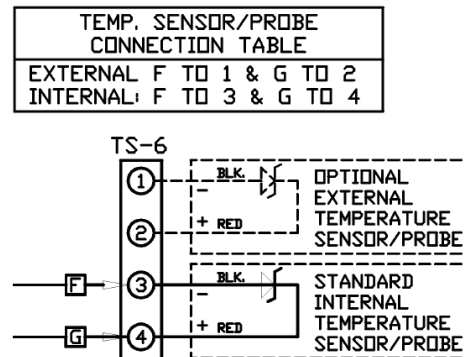

**Figure 10 – Temperature Compensation Connections (External and Internal)**

#### Procedure for Chargers with S2A-406 Board:

1. Locate the **J4** terminal strip on the S2A-406 board.
2. Toggle the **SW1** switch on the S2A-406 board to the External position. Refer to Figure 11.
3. Connect the black lead of the external probe to terminal **2** of **J4**, and the red lead to terminal **1** of **J4**.
4. Place the external probe in a desired location.  
(It is recommended that the battery manufacturer be consulted for placement of the probe)

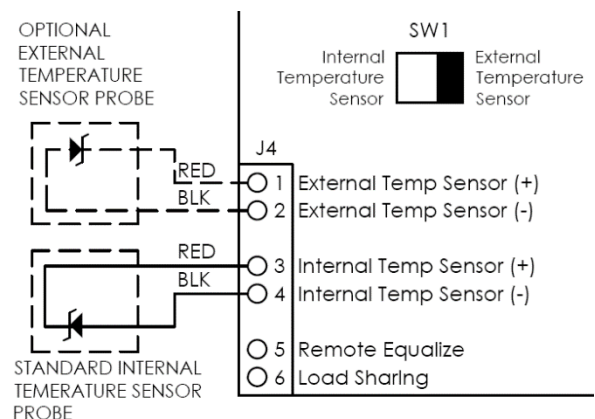

**Figure 11 – Temperature Compensation Connections (External and Internal for S2A-406 Board)**

## 2.6 Load Sharing

All A36D chargers include the Load Sharing feature. Load sharing allows the user to parallel with any identical A36D to share a DC load and therefore reduce the strain on each charger. When connected, identical A36D chargers are forced to share the load within  $\pm 5\%$  for individual unit outputs greater than 5% of the rated output. Chargers to be paralleled *MUST* be the same output (voltage and current). Load sharing only needs to be setup once. Upon recovery from an AC power failure, the chargers will automatically re-sync the load share.

If load sharing is to be used with a battery that requires periodic Equalize cycles, the chargers should also operate in Remote Equalize mode (See Section 2.7 for instructions).

### Load Sharing Procedure

Before making any connections to the A36D, ensure that the AC power is off at the main breaker box and that all of the chargers' breakers are off. Verify that no voltage is present by using a voltmeter at all input and output terminals.

#### Procedure for Chargers with S2A-255 Board:

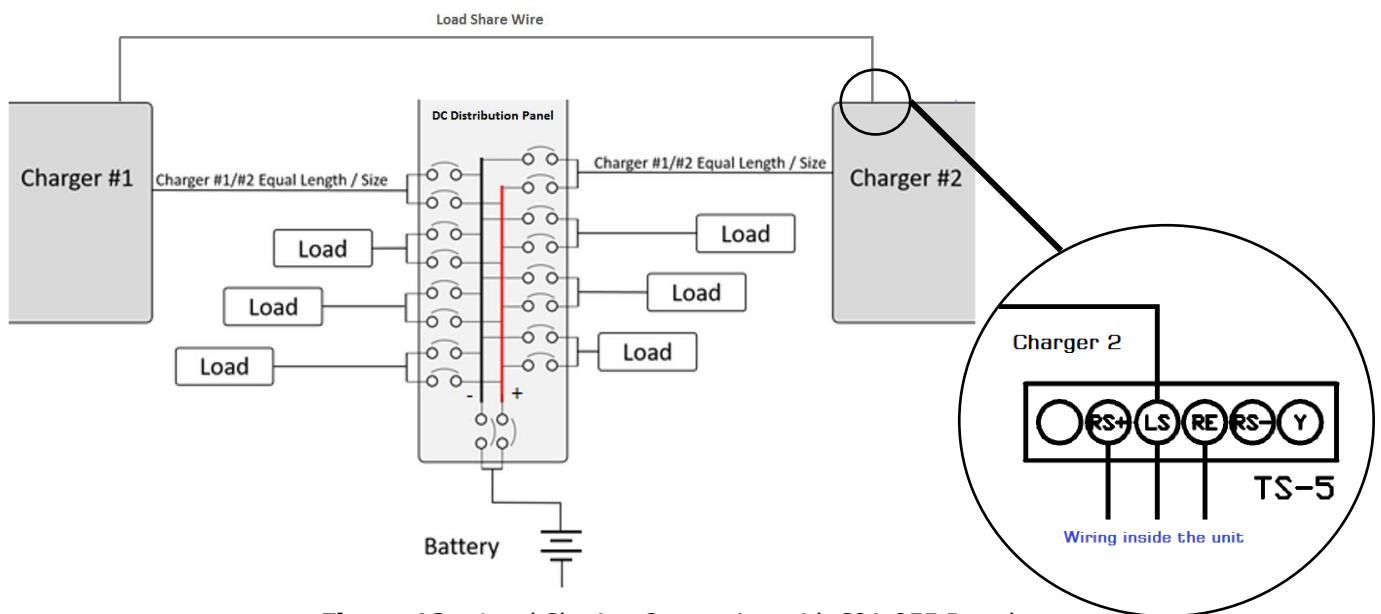

**Figure 12 – Load Sharing Connection with S2A-255 Board**

1. Connect the DC output of all chargers in parallel to the same DC load/battery.
2. Locate terminal strip **TS-5** inside the chargers.
3. Connect the **LS** terminal of one charger to the **LS** terminal of the next charger. Refer to the figure above.
4. Once batteries are fully charged and/or loads are stabilized, turn OFF all chargers except for one.
5. Take a voltage reading on the output of the charger.
6. Turn on the next charger, turn off the first charger.
7. Set the output voltage of the next charger to match the first by adjusting the Float voltage using the settings menu (refer to Section 4.1.1).
8. After all chargers have been adjusted, turn ON all chargers.
9. Follow the same procedure for setting the Equalize voltage.

## Procedure for Chargers with S2A-406 Board:

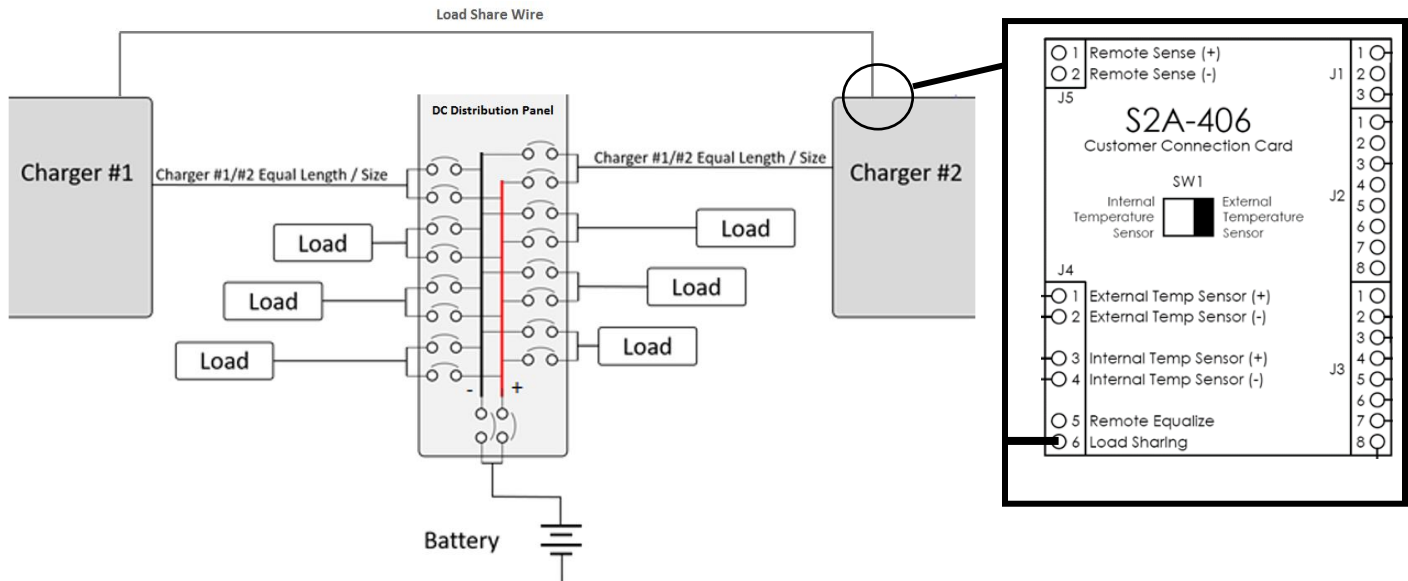

**Figure 13** – Load Sharing Connection with S2A-406 Board

1. Connect the DC output of all chargers in parallel to the same DC load/battery.
2. Locate terminal strip **J4** on S2A-406 board inside the chargers.
3. Connect terminal **6** of **J4** of one charger to terminal **6** of **J4** of the next charger. This connection can be made with a 16 AWG wire. Refer to the figure above.
4. Once batteries are fully charged and/or loads are stabilized, turn OFF all chargers except for one.
5. Take a voltage reading on the output of the charger.
6. Turn on the next charger, turn off the first charger.
7. Set the output voltage of the next charger to match the first by adjusting the Float voltage using the settings menu (refer to Section 4.1.1).
8. After all chargers have been adjusted, turn ON all chargers.
9. Follow the same procedure for setting the Equalize voltage.

### 2.7 Remote Equalize

A terminal is provided on charger for a Remote Equalize function. For chargers with the S2A-255 board, the Remote Equalize terminal is labeled "RE" and is located on the TS-5 terminal as shown on Figure 12. For chargers with the S2A-406 board, the Remote Equalize terminal is on terminal 5 of J4 as shown on Figure 13. Connections can be made by using a 16 AWG wire. The charger may be remotely forced into Equalize by connecting the Remote Equalize terminal to negative.

When chargers are connected for Load Sharing, they must also be set up to switch into Equalize at the same time. This can be accomplished by using the Remote Equalize function of the charger. In addition to wiring the Load Share wire, the chargers' Remote Equalize terminals must be connected together for Remote Equalize.

In a system, all charger Remote Equalize terminals are connected together and when any one master charger is put into Equalize, all chargers will go into Equalize and the display will read "in Remote Equalize." To return to Float Mode, the master charger must be returned to the Float Mode.



**CAUTION:** Damage to the unit will result if the Remote Equalize terminals are shorted to any other AC or DC voltage source or ground on positive grounded chargers.

**NOTE:** Remote equalize can only be used with other A36D battery chargers. If the user does not intend to use the Equalize function (VRLA batteries), the Remote Equalize connections are not required.

## 2.8 Remote Voltage Sensing

Provisions for remote DC voltage sensing are provided. The sensing circuit is activated when wires from the battery or load are brought back to the Remote Sensing terminals of the charger. For chargers with the S2A-255 board, the Remote Sensing terminals are labeled "RS+" and "RS-" and are located on the TS-5 terminal as shown on Figure 12. For chargers with the S2A-406 board, the Remote Sensing terminals are on terminals 1 & 2 of J5 as shown on Figure 13. Connections can be made by using a 16 AWG wire.

The positive remote sensing lead should contain an external 1 Amp fuse for negative ground system. When remote sensing is wired, the unit output may have to be readjusted to compensate for the protection diodes on the circuit board.



**CAUTION:** The polarity of the Remote Sensing terminals is critical. Check & verify the polarity carefully.

## 2.9 DNP 3.0 / Modbus SCADA Interface (Option 21P/21Q)

The optional DNP 3.0 / Modbus SCADA Interface Communication Board, allows the user to remotely connect to the A36D battery charger. The board is equipped with four methods of communication; DNP 3.0, Modbus ASCII, Modbus RTU and Modbus TCP. There are three different ports for connection to the communication board. The three port types for connection are: RS232, RS485, and TCP (Ethernet).

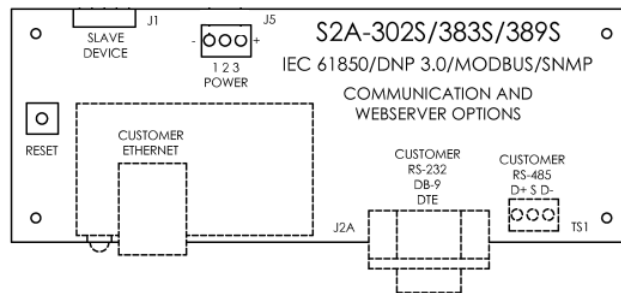

**Figure 14 – DNP 3.0 / Modbus Communication Board**

### Communication Interface Connection Procedure

Before making any connections to the A36D, ensure that the AC power is off at the main breaker box and the charger's breakers are off. Choose which port to use for connection (Ethernet, RS232, and/or RS485 – refer to the figure above). Connect the appropriate cable between the port on the communication board and the port on the computer.

For more details on connection instructions as well as operation instructions refer to the DNP 3.0 & Modbus SCADA Interface instruction manual included with the A36D. The DNP 3.0 & Modbus instruction manual is also available online at <http://www.lamarchemfg.com/>.

## 2.10 Battery Side Alarm Sensing (Option 565)

The optional battery voltage sensing board (S2A-407S) will allow the user to see the battery voltage, even when the charger DC breaker is open.

The Low Voltage and End of Discharge alarms are based on the voltage measured on the battery side of the DC breaker when Option 565 is used. In case of sensing board failure, a special alarm "S2A-407S Failure" and the Summary alarm will be triggered. Also, the controller will start using the charger side voltage sensing for Low Voltage and End of Discharge alarms.

### 3 Operation

#### 3.1 Starting the A36D

All equipment is shipped from the factory fully checked and adjusted based on the model number. Do not make any adjustments unless the equipment has been powered-up and the settings have been determined to be incorrect.

#### **Factory Settings**

The factory settings of the A36D are based on the model number. Unless otherwise specified, all chargers are set at the factory with the following settings:

Parameter	Lead Acid	VRLA	Nickel Cadmium	Delay (sec.)
Float Voltage	2.25 V/C	2.25 V/C	1.40 V/C	
Equalize Voltage	2.35 V/C	2.27 V/C	1.55 V/C	
Low DC Voltage	2.0 V/C		1.30 V/C	5
Low DC Voltage Reset	8% of the Low DC Voltage threshold			
Low DC Current	1% of the shunt size			5
Low DC Current Reset	Dependent on output current rating			
Overload	110% of the nominal output current			5
Overload Reset	5% of the Overload threshold			
Current Limit	115% of the nominal output current			5
High DC Voltage	2.45 V/C		1.60 V/C	5
High DC Voltage Reset	5% of the High DC Voltage threshold			
High Voltage Shutdown	2.50 V/C		1.65 V/C	20
Battery End of Discharge	1.75 V/C		1.10 V/C	5
End of Discharge Reset	5% of the End of Discharge threshold			
Equalize Timer Mode	Automatic Equalize Off (Mode P0)			
Equalize Time	8 Hours			

**Table 9** – Factory Default Values

**NOTE:** V/C – Volts per Cell, LA – Lead Acid, VRLA – Valve Regulated Lead Acid, NC – Nickel Cadmium

#### **Checking the Installation**

Before attempting to start up the A36D, check and verify that all connections are correct. Check that all terminations and contacts are tightened securely. Check that the transformer is set for the correct input voltage and that the input frequency matches the nameplate or the charger. Check that the battery/load voltage matches the DC output voltage on the nameplate of the charger.

### Start-Up Sequence

1. Close the AC Breaker. The charger LEDs should flash and firmware version should show on the display for approximately 2 seconds.
2. The charger output will slowly ramp-up to the target voltage (This can take up to 60 seconds).
3. Certain alarms will be active during ramp-up. These alarms will clear as the voltage climbs above the alarm thresholds.
4. Close the DC Breaker.

**NOTE:** If any of the above alarms are set to latching, the alarms will not clear automatically as part of the start-up procedure. After the charger has completed the start-up, clear the alarms using the Alarm Reset function in the menu.

### Power Down Sequence

To power down the A36D charger, first open the charger AC Breaker, then open the charger DC breaker(s).

### 3.2 Digital Control Board

The A36D is available with an LCD or VFD digital control board as Options 550 or 551 respectively. These options replace the LED analog control board that is standard to the A36D. The digital control board is a more attractive and user-friendly option, with many additional features over the standard LED analog control board.

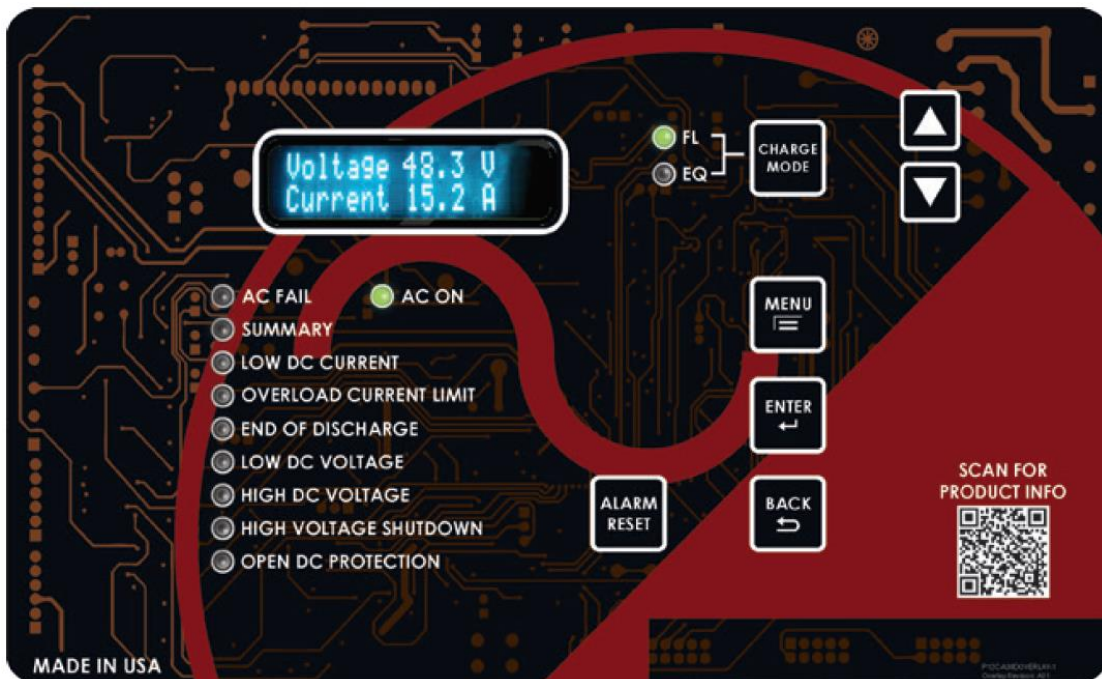

Figure 15 – A36D Front Panel

After the A36D has completed the startup sequence, "AC ON" and "FL" green LED indicators on the front panel will be lit, additional indicators will be lit according to the system's status as pictured above. The digital meter display will show both the system DC output voltage and DC output current. Pressing either the UP or the DOWN arrow on the membrane will change the parameter that is displayed.



The parameters viewable on the idle display are as follows:

Voltage 50.3 V Current 15.2 A	System DC Outputs	Temperature Compensation OFF	Temperature Compensation Status
EQ Timer Mode Auto EQ OFF	Selected Equalize Timer Mode	Temperature Probe 27C	Temperature at Probe (internal/external – based on connection)
Next Auto EQ in: OFF	Time until next automatic Equalize cycle	Date 2/5/2015 Time 11:54:19	Charger Clock Date and Time
EQ Timer OFF 8 Hour EQ	Equalize Timer Status and Length	Logging Status OK 0.01 Pct	Logging Status
		Next Batt Test: OFF	Time until Next Automatic Battery Test

### 3.3 Selecting the Charging Mode

The A36D has two different settings for DC output voltage, Float Mode and Equalize Mode. Float charging mode is used for all normal battery charging needs. Equalize Mode is used when it is necessary to Equalize (or balance) the level of charge across all cells present in the battery. Consult the battery manufacturer for the proper Equalize procedures. *Refer to Float/Eq voltage in Adjusting Parameters section for Float and Equalize voltage levels adjustments.*

There are two LEDs on the front panel that indicate the current mode of the charger. If the charger is in Float Mode, simply press the CHARGE MODE button to switch into Equalize Mode. If the charger is in Equalize Mode, it will automatically switch back to Float Mode after the designated Equalize time. Alternatively, the charger can manually be switched to Float Mode by pressing the CHARGE MODE button again.

#### 3.3.1 Equalize Timer Modes

The A36D battery charger has five different modes of Equalize charging operation. The Equalize Mode can be viewed on the charger display by pressing the down button. The Equalize Mode and the length of the Equalize timer can be changed via Settings Menu. In all of the Equalize Modes, the charger will immediately return to Float Mode if the CHARGE MODE button is pressed.

##### **Mode 0 (Auto EQ OFF)**

Mode 0 is a manual Equalize cycle and is the default setting for the charger. When the charger is set for Mode 0, the Equalize cycle must be activated manually. Once activated the Equalize timer will turn on and the "EQ" LED will light. The length of the timer is 8 hours by default. After the timer cycles to zero, the charger will automatically return to Float Mode. Equalize Mode will not start again until it is manually activated by the user.

##### **Mode 1 (7-Day Auto EQ)**

Mode 1 is an automatic Equalize cycle that activates every 7 days. The length of the Equalize cycle is determined by the timer setting. The length of the timer is 8 hours by default. After the timer cycles to zero, the charger will automatically return to Float Mode. Equalize Mode will restart again after 7 days.

##### **Mode 2 (14-Day Auto EQ)**

Mode 2 is an automatic Equalize cycle that activates every 14 days. The length of the Equalize cycle is determined by the timer setting. The length of the timer is 8 hours by default. After the timer cycles to zero, the charger will automatically return to Float Mode. Equalize Mode will restart again after 14 days.

### **Mode 3 (30-Day Auto EQ)**

Mode 3 is an automatic Equalize cycle that activates every 30 days. The length of the Equalize cycle is determined by the timer setting. The length of the timer is 8 hours by default. After the timer cycles to zero, the charger will automatically return to Float Mode. Equalize Mode will restart again after 30 days.

### **Mode 4 (Auto EQ on LV)**

Mode P4 is an automatic Equalize cycle that is triggered when the battery experiences a sizeable discharge. When the DC voltage drops below the Low Voltage alarm threshold and exceeds the Low Voltage alarm time delay, Mode 4 is activated. However, the Equalize timer will only start and run the charger in Equalize mode for the duration set in the Equalize menu after the charger has raised the battery voltage high enough to clear the Low Voltage alarm. When the Equalize timer expires, the charger will immediately return to Float mode.

## **3.4 Output Voltage Adjustments**

The output voltage of the A36D charger is set to a default value, but should be adjusted to meet the battery manufacturer recommendations. To adjust the Float and Equalize output voltage, refer to Section 4.1.1. Adjustments are recommended to be made with no connections on the DC output terminals of the charger, but can also be done with the battery connected. Output adjustments can be carefully made with the charger energized until the desired voltage is achieved.

### **NOTES:**

- 1. When making output voltage adjustments with batteries connected, the immediate change will be reflected on the output current and NOT the voltage due to the voltage difference between the output and the batteries.*
- 2. In parallel systems, each charger MUST be isolated to properly perform output voltage adjustments.*

## 4 Controller Menus

The A36D controller is equipped with multiple settings and test menus. Refer to the Appendix B for details on the structure of the charger menus. Access menus by pressing the MENU button on the front panel. Navigate using the UP and DOWN arrows. To enter a submenu, use the ENTER button. The BACK button returns to the previous menu. When making a selection, the ENTER button will store the value and step back. The BACK button will not save the change and will go a step back. At any point, the settings menu can be exited, with or without saving the settings.

### Saving Settings

At any point, the user can press the BACK button from the main Settings Menu to exit the Settings Menu. When the back button is pressed (on the main Settings Menu), the user is prompted if they would like to "Exit and Save Settings?" If the BACK button is pressed again, the control board will return to the Settings Menu. If "YES" is selected, the display will read "Saving Settings", the menu will be exited and settings saved. If "NO" is selected, the user is prompted to "Exit without Saving?" From this screen, if "YES" is selected, the user will be returned to the DC output display and all changes to the settings will not be saved. If "NO" is selected, the user will be returned to the Settings Menu.

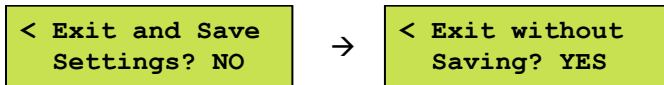

### 4.1 Settings Menu

All equipment is shipped from the factory fully checked and adjusted based on the model number. Do not make any adjustments unless the equipment has been powered-up and the settings have been determined to be incorrect. If the settings have been determined to be incorrect, adjustments may be made as detailed below. Refer to Appendix B for A36D customer configuration menu structure.

In the Settings Menu, the user can access and change various parameters used by the A36D. To access the Settings Menu, press the MENU button, select "Settings Menu", and press the ENTER button.

**NOTE:** Some chargers may have additional settings included in the Settings menu; contact La Marche for further explanation of settings not mentioned below.

#### 4.1.1 Float/EQ Voltage/Current Limit

The Float/eq Voltage/Current Limit submenu provides access to change the Float Voltage, Equalize Voltage, and Current Limit settings.

##### Float Voltage Setting

The float voltage adjustment is set at the factory at 2.17 V/C (LA), 2.25 V/C (VRLA) or 1.4 V/C (NC). The Float voltage increments by 0.1V. Select "Float Voltage Setting" and press then ENTER button. Press the UP and/or DOWN buttons until the required voltage level is displayed. Press ENTER to store the setting or BACK to cancel.



##### Equalize Voltage Setting

The Equalize voltage adjustment is set at the factory at 2.33 V/C (LA), 2.27 V/C (VRLA) or 1.55 V/C (NC). The Equalize voltage increments by 0.1V. Select "Equalize Voltage Setting" and press then ENTER button. Press the UP and/or DOWN buttons until the desired voltage is displayed. Press ENTER to store the setting, BACK to cancel.



### Current Limit

The Current Limit adjustment allows the user to adjust the maximum current output of the charger. The Current Limit is adjustable between 50% and 115% of the nameplate rating, with a default setting of 110%. The Current Limit setting is adjustable in 1% increments.

**NOTE:** Adjust the Overload alarm to correlate with any current limit adjustments for the charger to alarm when the overload/current limit condition is met.

### 4.1.2 Alarm Settings

The Alarm Settings submenu provides access to the change the Alarm Thresholds and Summary Alarm Selects.

#### Alarm Thresholds

The Alarm Thresholds setting allows the user to determine the current or voltage value at which an alarm trigger. The threshold can be changed for Low Current Alarm, Low Current Alarm Reset, Overload Alarm, Low Voltage Alarm, Low Voltage Alarm Reset, End of Discharge Alarm, High Voltage Alarm, and High Voltage Shutdown Alarm.

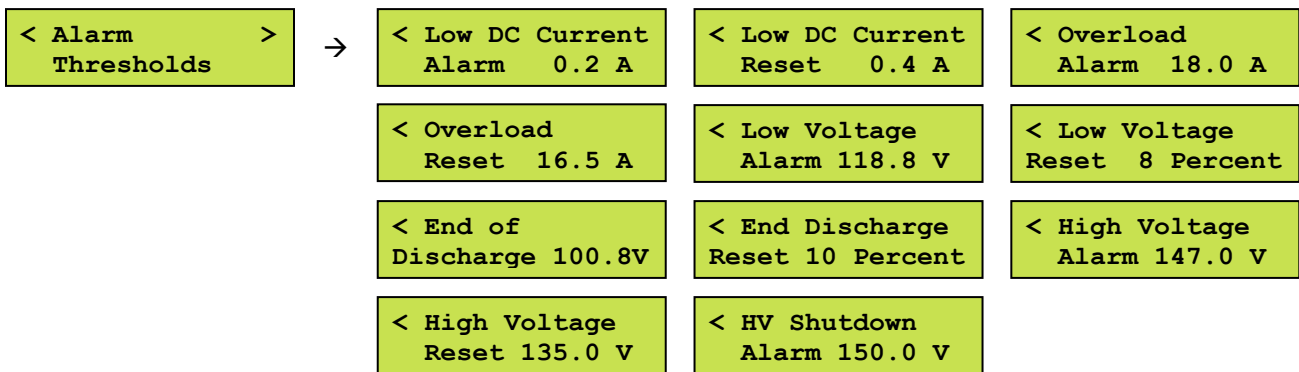

**NOTE:** Alarm threshold defaults are based on the charger output. The alarm threshold values shown above are not representative of the default values for any specific A36D charger.

#### Summary Alarm Selects

The Summary alarm selects setting allows the user to choose whether or not to include the Low Current Alarm and AC Failure Alarm as part of the Summary Alarm. By default, both of these alarms are included in the Summary Alarm.

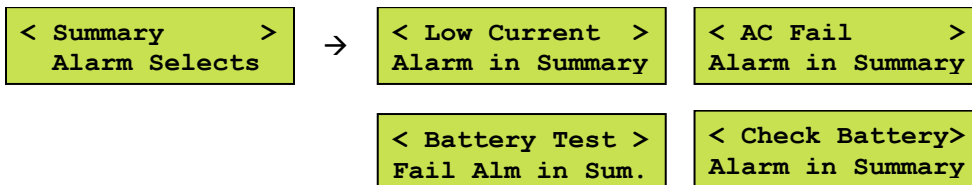

**NOTE:** The Low DC Voltage and High DC Voltage alarms are included in the Summary alarm and cannot be removed.

### 4.1.3 Advanced Settings

The Advanced Settings Menu allows the user to access and modify other parameters of the charger which are not included in the basic Settings Menu. The Advanced Settings Menu is divided into 7 submenus: "Equalize Timer Settings", "Advanced Alarm Settings", "Temperature Compensation", "Communication Settings", "LCD Settings", "Return to Defaults", "Clock Settings", "Serial Number", "Firmware", and "Logging and Files".

### **Equalize Timer Settings**

The Equalize Timer Settings submenu provides access to the change the Equalize Timer Mode, and Equalize Timer Hours.

#### Equalize Timer Mode

The Equalize timer mode determines when the charger will go into an Equalize charging cycle. The timer modes are "Auto EQ OFF", "7 Day Auto EQ", "14 Day Auto EQ", "30 Day Auto EQ", and "Auto EQ on LV". The default setting for the Equalize timer mode is Auto EQ OFF. The Equalize Timer Modes are discussed in further detail in Section 3.3.1.

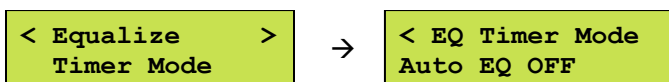

#### **Equalize Timer Hours**

The Equalize timer hours setting changes the amount of time that the charger remains in the Equalize charging cycle once activated. When an Equalize cycle is started the charger will remain in Equalize Mode until the time selected by this setting has passed. The Equalize timer can be set between 1-144 hours, by default the Equalize timer is set for 8 hours. The battery manufacturer recommendations should be followed.

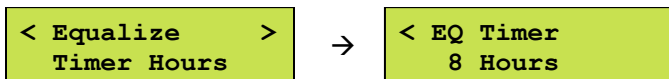

### **Advanced Alarm Settings**

The Advanced Alarm settings allow the user to access and modify additional parameters of the charger, such as the Alarm Delays and Alarm Operation.

#### **Alarm Delays**

The Alarm Delays setting allows the user to determine the time delay between the alarm condition and alarm indication. If an alarm condition returns to normal before the delay time, the alarm will not indicate. The delay can be changed for Overload Alarm, End of Discharge Alarm, AC Alarm, Low Current Alarm, Low Voltage Alarm, High Voltage Alarm, High Voltage Shutdown Alarm, and Auto EQ on Low Voltage (EQ Mode 4). The delay for all alarms is adjustable between 1-300 seconds.

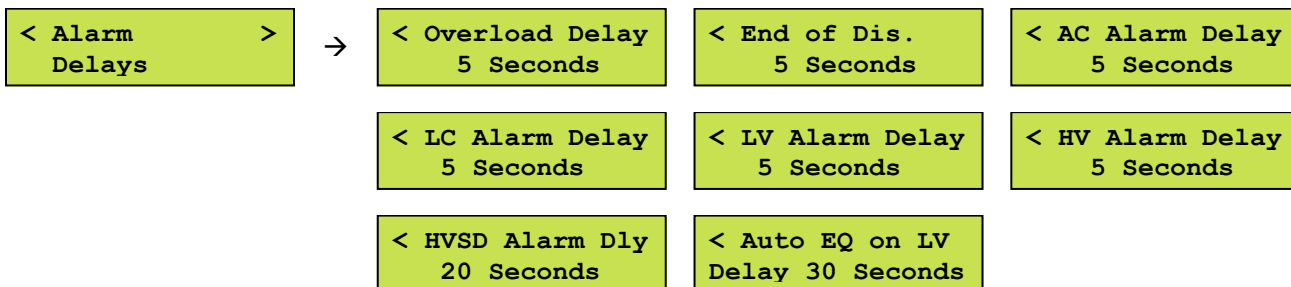

#### **Alarm Operation**

The Alarm Operation setting defines if the alarms relays latch. The relay latch setting can be changed for Summary Alarm, AC Power Fail Alarm, Low Current Alarm, Low Voltage Alarm, High Voltage Alarm, and Open DC Protection Alarm. If any alarm contacts are set to latch, the alarm will not clear until the ALARM RESET button is pressed, even if the alarm condition returns to normal.

By default, no alarms are set as latching, except for High Voltage Shutdown (HVSD). All other alarms will clear after the condition returns to normal.

**NOTE:** The HVSD alarm latches by default and cannot be changed.

### Temperature Compensation Settings

Temperature Compensation is a standard feature of the A36D charger. Temperature Compensation adjusts the output voltage of the charger based on the temperature at the probe. To enable Temperature Compensation, select "Temp. Comp." in the Advanced Settings menu. Temperature Compensation is adjustable between OFF and 0.001 to 0.004 volts/cell/°C.

*Ex: The output of a 24L charger with Temperature Compensation set to 0.002V/Cell/°C would decrease by 0.048V for every 1°C increase in temperature.*

### Communications Settings

The communication settings menu changes depending on the type of communication protocol used in the charger. For details on connection instructions as well as operation instructions, refer to the SCADA Interface instruction manual included with the charger.

#### Chargers with DNP 3.0 Communication Protocol (Option 21P)

Setting	→	Default Setting (Selection)
DNP Node Address	→	0004
DNP Port Type	→	RS485 (RS485, RS232)
DNP Parity Type	→	None (None, ODD, EVEN)
DNP Baud Rate	→	9600 (1200, 2400, 4800, 9600, 19200, 38400)
DNP IP Address	→	192.168.000.006
DNP Subnet Mask	→	255.255.255.000
DNP Gateway	→	192.168.000.001
DNP TCP Port Number	→	20000
Read Only Mode	→	No (No, Yes)

#### Chargers with MODBUS (Option 21Q)

Setting	→	Default Setting (Selection)
Modbus Type	→	TCP (TCP, Serial)
Modbus Address	→	1 (1 – 247)
Modbus Baud Rate	→	9600 (1200, 2400, 4800, 9600, 19200, 38400)
<i>(Setting available only if Modbus Type is set to Serial)</i>		
Modbus Parity Type	→	None (None, ODD, EVEN)
<i>(Setting available only if Modbus Type is set to Serial)</i>		
Read Only Mode	→	No (No, Yes)

**NOTE:** For TCP settings, see SCADA Interface instruction manual included with the charger.

#### Chargers with MODBUS RTU (Option 21S)

Setting	→	Default setting (Selection)
Modbus Type	→	Serial Only
Modbus Address	→	1 (1 – 247)
Modbus Baud Rate	→	9600 (1200, 2400, 4800, 9600, 19200, 38400)
Modbus Parity Type	→	None (None, ODD, EVEN)
Read Only Mode	→	No (No, Yes)

### LCD Settings

The LCD settings allow the user to control the LCD backlight. By default, the LCD backlight automatically turns off after two minutes. The user may also set it to be always on. If the charger was ordered with a VFD control board, this option will not be available.

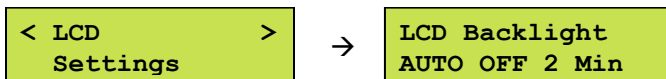

## ***Return to Defaults***

The "Return to Defaults" menu allows the user to load the factory default settings for all parameters not included in the Advanced Settings menu. Loading basic default settings will not reset any settings included in the advanced section of the Settings menu.

## ***Clock Settings***

The "Clock Settings" submenu allows the user to program the real-time clock used by the software. This clock is used in the data logging to timestamp events. In addition, the clock can be reset, which returns the clock to the date setting of software revision.

## ***Serial Number***

The "Serial Number" setting allows the user to change the serial number associated with the S2A-341S board. This serial number is the serial number of the A36D charger and is set at the factory for new chargers. If a user receives a replacement S2A-341S board, the serial number will have to be set via calibration.

In order to change the serial number used by the software, select "Serial Number" from the Settings menu and press the ENTER button. Each digit of the serial number is adjusted individually. Press the CHARGE MODE button to move to the next digit. Press the UP and DOWN buttons to increase and decrease the selected digit.

## ***Firmware***

The Firmware Menu allows the user to view the firmware version, as well as update the firmware if desired. The submenus are as follows:

### ***Version Information***

The menu allows the user to view the current firmware version of the charger.

### ***Update Firmware***

The A36D firmware can be updated, as a standard feature, via a microSD card. To update the firmware, follow the procedure below:

***NOTE:*** *If more than one firmware .bin file is on the microSD card, the bootloader will not program or reprogram the flash and will show a message saying, "More than 1 file found!" and will loop forever.*

*If no firmware .bin file is on the microSD card and the program flash is empty, the bootloader will loop forever and display the message "No update file found!"*

1. Save the settings .csv files by following the steps shown on the previous page under *Save Settings*.
2. Remove the microSD card by entering the Settings Menu: (Menu → Settings Menu → Advanced Settings → Logs and Files → Remove Drive).
3. Insert the microSD card into the computer using a microSD card converter.
4. Back up all files in the microSD card to the computer.
5. Format the microSD card by following the steps under *Formatting the microSD Card* on page 27.
6. Find the firmware .bin file provided and upload it into the microSD card.
7. Safely remove the microSD card from the computer and insert it on the A36D charger's microSD card slot by following the installation instructions in Section 5.0 under *Installing/Removing the MicroSD Card*.
8. Update the firmware by entering the Settings menu: (Menu → Settings Menu → Advanced Settings → Firmware → Update Firmware)
9. Enter the password provided (must contact La Marche Service Department) and select YES when prompted to update the firmware. The charger will start to program itself. Do **NOT** interrupt the power or the board while it is programming!
10. Save the settings .csv files once again, as well as the configuration .cfg file by following the steps shown on the previous page under *Save Settings* and *Save Config Files* respectively.

## ***Logging and Files***

The "Logging and Files" menu allows the user to access the A36D Data Log and make changes to the Data Log settings. It also allows downloading and uploading charger configuration files. The submenus are as follows:

### **Remove Drive**

The "Remove Drive" option must be used prior to removing the microSD card from an energized charger. This prevents damage to the microSD card data. Refer to Appendix C for removal instructions.

### **Insert Drive**

The "Insert Drive" option must be used prior to installing the microSD card into an energized charger. This prevents damage to the microSD card data.

### **Data Logging**

The A36D now includes data logging as a standard feature. The log file is written as a .csv file. The "Data Logging" menu allows the user to adjust settings related to data logging. For more information on data logging, see Section 5. The submenus are as follow:

#### ***Enable Event Log***

The "Enbl Event Log" option allows the user to enable Event type logging. By default, Event Logging is enabled.

#### ***Logging Interval***

The "Logging Interval" option allows the user to set the interval that data is logged. By default, the interval is set to 60 minutes, but can be adjusted from 1 to 60 minutes.

#### ***Format Drive***

To initialize a memory card for use in the A36D, select "Initialize" from the "Config Files" menu and follow the prompts. Initializing a microSD card will erase all data from the card; it is required to use a blank and formatted microSD card for use. Refer to Section 5.3 under *Formatting the MicroSD Card* for formatting instructions. A memory card only needs to be initialized once. After it has been initialized in a charger, it can be used in any other A36D charger without being initialized again.

#### **Save Settings File**

The "Save Settings" menu allows the user to create a read-only customer and factory settings .csv file which is saved into the inserted microSD card. The files contain supportive information on factory settings of the charger and the customer settings of the charger. Should any issues arise and service department is required to be contacted, these files may be downloaded.

#### **Upload Config File**

The "Logging and Files" menu contains the options for saving or loading a configuration .cfg file. In order to properly transfer a configuration file, a microSD card must be initialized first. After the memory card has been initialized, the configuration can be saved.

To load an existing configuration file, insert a microSD card with a previously saved configuration file. Select "Upload Config File" and follow the prompts. After a configuration .cfg file is loaded, it is recommended to check the settings to verify that they are correct for each charger.



## Save Config File

The A36D charger enables the user to save and load a configuration .cfg file to an installed microSD card. A saved configuration file can be loaded to multiple A36D chargers to ease set up time if an installation has more than one A36D charger. Take into consideration all A36D chargers must be of the same model number and firmware version.

To save a configuration file, insert a microSD card into the S2A-341S board, initialize the memory card, and select "Save Config File" menu. If a configuration .cfg file already exists, it will be overwritten.

**NOTE:** In order to prevent data loss, the "Remove Drive" option must be selected before physically removing the microSD card.

### 4.1.4 Return to Defaults

The "Return to Defaults" menu resets all user-adjustable settings to the factory defaults. It is important to note that the factory defaults are not necessarily the correct settings for the specific DC system. Before the charger is shipped, adjustments are made at the factory using the same calibration procedure. If the charger is reset to default, these factory changes may be reset.

**EXAMPLE:** The software default for a 48V charger is based on 24 lead cells, a 26L charger is factory adjusted for a higher voltage. Returning to default will return the charger to a 24L voltage setting.

```
< Return to >  
Defaults
```

## 4.2 Test Menu

All equipment is shipped from the factory fully tested and operational. As part of planned maintenance, users may want to be able to re-test functionality of the alarm LEDs and relays. The Test Menu allows the user to test both the LEDs on the display board as well as any alarm relay contacts.

### 4.2.1 Test LEDs

The Test LEDs menu allows the user to run a basic lamp test on the A36D. After selecting this menu, press the "ENTER" button to light all of the LEDs on the display membrane. To end the LED test, press back.

```
< Test >  
LEDs → < LED Test >  
Press ENTER → < End LED Test >  
Press BACK
```

**NOTE:** Any additional LEDs on auxiliary boards will not be affected by this LED test.

### 4.2.2 Test Relays

The test relays menu allows the user to test the functionality of the alarm relay contacts. The menu allows for each contact to be tested individually, or all at once. When a relay is being tested, its contacts will change state. This means if a relay is in alarm state, it will revert to the non-alarm state during relay testing. The HVSD alarm is not included in either of the other tests, but instead, has its own test menu.

```
< Test >  
Relays → < Test ALL >  
Contacts at Once < Test Contacts >  
Individually < Test HVSD >  
Alarm Contacts
```

When an alarm relay is being tested, the corresponding LED on the membrane will change state. There are no relay contacts for the "OVERLOAD/CURR. LIMIT" or "END OF DISCHARGE" alarms; these LEDs will not be lit under the relay test. As with the LED test, once the appropriate selection is made, press the "ENTER" button to start the test and the "BACK" button to end the test.

### 4.2.3 Test Battery

The Test Battery menu allows the user to manually perform the battery test or setup for a periodic automatic test. The automatic test can be set up to perform the test every 1, 7, 14, 21, 30, and 60 days.

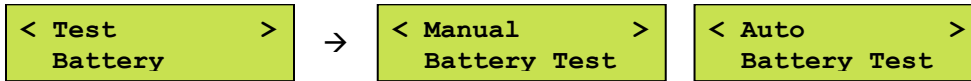

However, the following conditions must be met for the charger to initialize a battery test:

- The unit(s) must be in Float Mode
- No alarms must be present
- The load must be less than 50% of the load rating of the charger

The Battery Test alarm, as well as the Summary alarm if enabled, is triggered when the battery test is initiated. Whether initiated manually or automatically, the DC bus voltage will fall below one of the alarming thresholds. When the battery test is started, the charger voltage will drop to the appropriate test voltage (1.85 V/C for Lead Acid or 1.11 V/C for Nickel Cadmium). After 35 seconds, the charger will take a reading of the DC bus voltage and indicate one of three conditions:

- "Battery Test: PASSED" – DC voltage higher than 2 V/C LA or 1.2 V/C NC
- "Battery Test: CHECK BATTERY" – DC voltage between 1.9 – 2.0 V/C (for LA) or 1.14 – 1.2 V/C (for NC)
- "Battery Test: FAILED" – DC voltage below 1.9 V/C LA or 1.14 V/C NC

**NOTE:** V/C – Volts per Cell, LA – Lead Acid, NC – Nickel Cadmium

If the battery test result concludes in either CHECK BATTERY or FAILED, the following will occur:

- The display will show the corresponding alarm on the main screen
- The Summary alarm LED and contacts will activate (if applicable)

The Summary alarm activation is optional and can be configured. Please refer to Section for options. To clear the alarm, simply press the ALARM RESET button on the front panel of the charger.

### 4.3 Reset All Alarms

The "Reset All Alarms" menu allows the user to reset all alarms.

### 4.4 Last 10 Events

Displays the last 10 events that have occurred on the front screen of the charger. This is to be used as a quick reference. If more detail is required, refer to Section 5 for the data logging information. The events that are logged are: Alarm Occurrence, Alarm Cleared, Change in Charge Mode, and Charger Reset.

## 5 Data Logging

The A36D now includes data logging as a standard feature. The log file is written as a .csv file format which can be opened using Microsoft Excel or any number of free spreadsheet programs. It can even be opened on many modern smartphones. The data logs are written to an included microSD card, which plugs into a slot located at the top left of the S2A-341S board (when looking at the back of the front door). The data log can be set to log Charger Events, as well as to log all data at a specified interval. By default, the log file is set to Events only.

The microSD card can be removed, following the proper menu prompt, and has various files included as seen on the figure aside. The two data files are SETTINGS.csv and EVENTS.csv, which can be downloaded to a computer for easy review. A microSD card reader adapter will be necessary to interface with a computer. Refer to Appendix C for instructions.

**NOTE:** The *position.bin* file is written to the microSD card. This file is important to the function of the data logging and should never be modified or deleted.

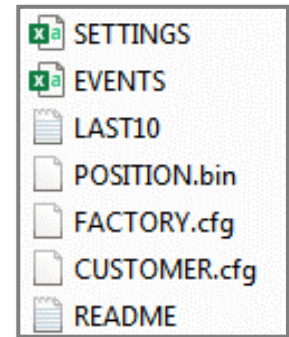

The following guidelines should be taken into consideration:

- Only use microSD cards provided by La Marche.
- Do not use the microSD card for any other purpose besides data logging and firmware updating. Data corruption/microSD card damage may occur.
- Do not touch metal contacts on the back side of the microSD card when handling.
- MicroSD card to be used MUST be blank and formatted. To format the microSD card, install it on a PC and run a full format.

### 5.1 Events Only Logging

The Events Only Logging records data only when an event occurs. When an event occurs, all charger data points are written to better understand the cause of said event. The events that are logged are: Periodic Log, Alarm Occurrence, Alarm Cleared, Settings Menu Entered, Settings Menu Exited, Change in Charge Mode, and Power On Reset.

At any event occurrence, the data log file will record the date, time, DC Voltage, DC Current, Over Temperature Probe (°C), Temperature Compensation Probe (°C), as well as the event which occurred.

### 5.2 Interval Logging

Interval Logging records a log file that records data continuously at a specified time interval. In addition, any charger event will be recorded at the time of occurrence. The interval log records all of the same data as is listed above. The default interval when set up is 60 minutes and is adjustable between 1 to 60 minutes with 1-minute increments. Interval Logging can be very beneficial in DC system troubleshooting by keeping a record of all data leading up to a logged event.

### 5.3 Formatting the MicroSD Card

The microSD card may need to be formatted for the following reasons:

- Installing a new microSD card sourced from a 3<sup>rd</sup> party
- Data on original microSD card has been found corrupt and non-usable
- Other non-charger data has been detected on the microSD card
- If the A36D charger does not recognize the microSD card

There are two acceptable procedures to format the microSD card. It is important that only these two methods are used, as the A36D charger does not run a Windows-style NTFS, FAT, or FAT-32 based sector partition scheme. If the microSD card has been formatted to one of these partition schemes, the card may have trouble maintaining data after several months of records. It should also be noted the microSD card should not contain pictures, microSD card management software, or any other non-intrinsic charger data.

Please be advised that formatting the microSD card will completely erase any data; make a copy of any desired data on your PC prior to formatting. Formatting will create the microSD card sector partitions; these are the blocks where bytes of data are divided and shared.

#### MicroSD Card Format Method 1 (Preferred):

The A36D can properly format the microSD card with its built-in initialize function. With the microSD card installed in the charger, press MENU → Settings Menu → Advanced Settings → Logging and Files → Data Logging → Format Drive. The charger will ask you if you want to erase all data, select yes. The microSD card is now ready to be used in the charger.

#### MicroSD Card Format Method 2 (Requires Internet Connection & Admin Rights):

With the microSD card installed in your PC, go to the following link and follow their directions to install. <https://www.sdcard.org/downloads/formatter/>.

After accepting the terms, it will download a ZIP file containing an installation executable program: "MicroSD Card Formatter"; install the program.

Once installed, insert your microSD card and open the "SD Card Formatter" program (See image below). To format, select the microSD card, check "Overwrite Format", then click "Format". A warning message will be given that formatting will erase all data on the card, click "Yes"; see image. The program will begin to fully format and partition the data sectors. When formatting is complete, an indication message will be received; see image.

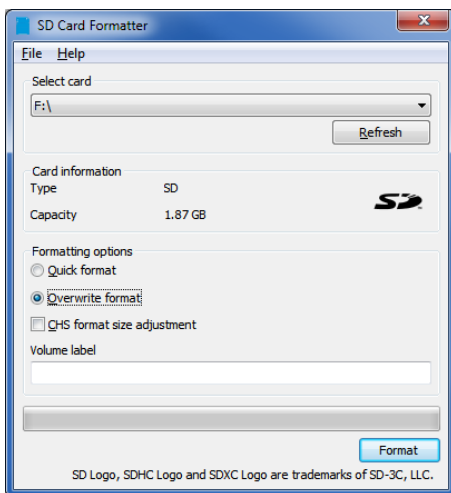

**Figure 1 – SD Card Formatter Program with Overwrite Format Checked**

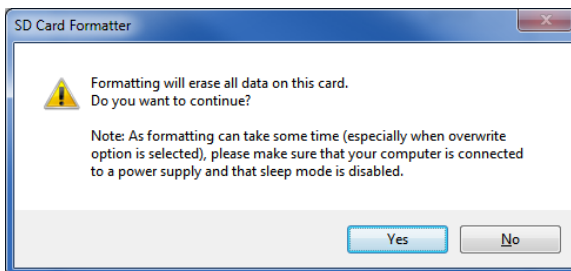

**Figure 2 – Warning Message About Erasing Data**

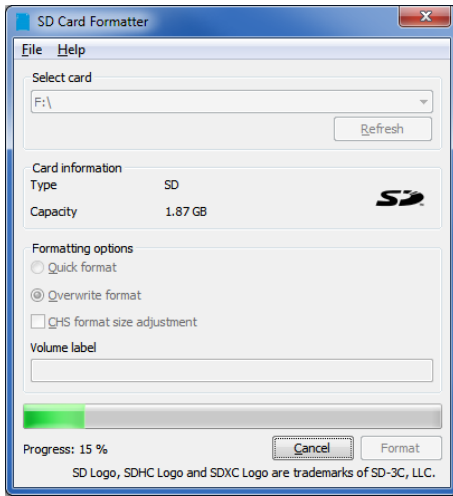

**Figure 3 – Formatting in Progress**

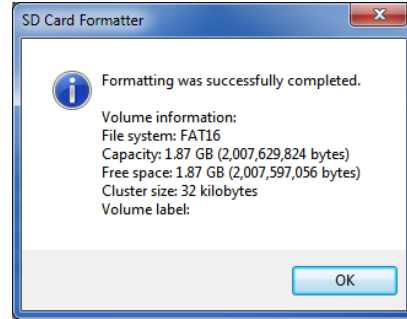

**Figure 4 – Formatting Successful Message**

After either format method is complete, it is advised to save the charger’s configuration .cfg file to the microSD card. See Section 4.1.3 under *Save Config File* on how to save the configuration .cfg files.

#### 5.4 Installing/Removing the microSD Card

Installing/Removing the microSD card requires opening the door of the battery charger and the necessary precautions must be considered; dangerous voltage can be present inside the charger. Prior to removing or inserting the microSD card, refer to Section 4.1.3 to install or remove the microSD card. Failure to properly remove or install the microSD card can result in corrupt data or microSD card failure. To remove, prompt the Settings Menu for removal, then simply push in to release the microSD card from its mounting slot. To install, prompt the Settings Menu for inserting, then simply push in to insert the micro microSD card into its mounting slot.

#### 5.5 Reading the Log File

The data log file is written as EVENTS.csv. There may be other files written to the microSD card as well, but the events and/or interval logging is written entirely to the EVENTS.csv file.

**NOTE:** A hidden file, *position.bin*, is written to the microSD card. This file is important to the function of the data logging and should never be modified or deleted.

Simply open the EVENTS.csv file with the spreadsheet software of choice. The file looks similar to the figure shown below. At any event occurrence (or each specified interval), the data log file will record the date, time, DC Voltage, DC Current, Over Temp. Probe (°C), Temp. Comp. Probe (°C), as well as any event that occurred.

```

LaMarche Mfg. Company A36D Event Log File
Created on 01/01/2020 at 16:05:55
Charger Serial Number 000000-00
Firmware P341S0100 000000

```

Date	Time	DCV (V)	DCA (A)	TC PROBE	OT PROBE	BATTERY (V)	PROBE #1	PROBE #2	Event	
1/1/2020	16:05:56	132	0	25	0	-----	-----	-----	Settings Menu Exited	Settings Saved
1/1/2020	16:05:58	131	0	25	0	-----	-----	-----	Saving Settings in Flash	
1/1/2020	16:05:59	131	0	25	0	-----	-----	-----	Erase Sector 28 OK	
1/1/2020	16:05:59	131	0	25	0	-----	-----	-----	Write Sector 28 OK	
1/1/2020	16:05:59	130.9	0	25	0	-----	-----	-----	Erase Sector 29 OK	
1/1/2020	16:06:00	130.9	0	25	0	-----	-----	-----	Write Sector 29 OK	
1/1/2020	16:07:20	129.3	7.3	24	0	-----	-----	-----	Summary Alarm OK	
1/1/2020	16:07:20	129.3	7.3	24	0	-----	-----	-----	Low DC Current Alarm OK	
1/1/2020	16:10:06	129.5	7.2	25	0	-----	-----	-----	Settings Menu Entered	
1/1/2020	16:10:12	129.7	7.2	25	0	-----	-----	-----	Drive Removed	
1/1/2020	16:11:08	129.3	7.2	25	0	-----	-----	-----	Drive Inserted	
1/1/2020	16:11:16	129.7	7.2	25	0	-----	-----	-----	Settings Menu Exited	Settings Saved
1/1/2020	16:11:18	129.6	7.2	25	0	-----	-----	-----	Saving Settings in Flash	

**Figure 16 – Events Log Example**

## **6 Frequently Asked Questions**

### **Q: How can I tell what options are included on my A36D charger?**

A: Every charger will have a dedicated manual cover sheet included with the charger manual, which lists all the options included. If the manual that shipped with the charger is no longer available, call La Marche and provide the five-digit accessory code at the end of the model number.

### **Q: Can two A36D chargers be connected in parallel?**

A: Yes, two or more A36D chargers can be connected in parallel as long as they are of the same output voltage rating. Paralleling is to not be confused with load sharing. Refer to Section 3.6 for output voltage adjustments with units in parallel.

### **Q: Can the A36D charger settings be changed to accommodate charging Nickel Cadmium batteries instead of the intended Lead Acid battery, or vice versa?**

A: The necessary adjustments can be made, but are dependent on model and number of cells that will be used. The change that will be necessary for every model type is the output voltage adjustment; call La Marche to verify that the charger in question will have the necessary output range. Alarm thresholds will also need to be changed to the desired battery type defaults, refer to Section 4.1.2 for procedure and Section 3.1 for default values.

### **Q: If equipped with alarm contacts, can the alarm contact reference on the charger schematic be used for determining connections?**

A: Not completely. The charger schematic, for a charger with the option included, will show an alarm relay board with contact indication. However, all the contacts are shown in resting state, which is not true when the charger is energized. The charger schematic should also include an alarm contact table that specifies which relays are energized during normal operation, and which are not. Refer to Section 2.4 for more information.

### **Q: Why is there a Low Current alarm and can it be disabled?**

A: A Low Current alarm can be triggered by various conditions, but not all are considered to be severe. A common condition encountered is the batteries reaching nominal voltage and being fully charged with no constant load present. At this point, the charger is providing trickle charge to the batteries with minimal current draw and indicating a known low current condition. If this is the case, refer to Section 4.1.2 for disabling instructions. More severe conditions include charger failure, loss of AC power, maladjustment of output voltage, and possible disconnection of DC loads. If this is the case, other alarms will also be present.

## 7 Service

All work inside the A36D charger should be performed by qualified personnel. La Marche is not responsible for any damages caused by an unqualified technician.



Before working inside the A36D, ensure the AC power is off at the main breaker box and the battery has been removed from the charger's DC output terminals, either by removing the battery cables or exercising the battery disconnect. Verify that no voltage is present by using a voltmeter at all input and output terminals.

### 7.1 Performing Routine Maintenance

Although minimal maintenance is required with La Marche chargers, routine checks and adjustments are recommended to ensure optimum system performance.

#### Yearly

1. Confirm air vents are open. Remove dust and debris from interior of unit.
2. Verify all connections are tight.
3. Perform a visual inspection on all internal components.
4. Check front panel meters for accuracy and LED operation.
5. Measure the output ripple:
  - Without interrupting a live system, measure ripple at the DC output terminals of the charger with a True-RMS multimeter in the AC voltage setting. If the ripple reading is higher than the specified value in the table below, the capacitors are recommended to be replaced.

Charger Nominal Output	AC Ripple Limit
12VDC – 48VDC	30mV RMS

#### 7th Year

1. If the charger is consistently operated in higher temperature environments, all capacitors are recommended to be replaced.

#### 10th Year

1. Check magnetics, components and wiring for signs of excessive heat.
2. It is recommended to replace all capacitors if not done so at the 7-year interval.

## 7.2 Troubleshooting Procedure

Troubleshooting should be performed only by trained service personnel or experienced electricians. Before setting up any complicated testing or making any conclusions, inspect the charger using the guide below.

Check the following:

1. Check DC output cables, connections, battery type, and number of cells against the charger's rating.
2. Check charger specifications against customer order.
3. Check input connections, input voltage, and breaker size.
4. Check for shipping damage, loose connections, broken wires, etc.
5. Certain failures can be caused by defective batteries and customer loads; make sure batteries and loads are free from defects.

**NOTE:** *If the problem is found to be located in the printed circuit boards, the board should be replaced. No attempt should be made to repair circuit boards in the field.*

La Marche Service Technicians are available to help with troubleshooting or with scheduling charger service. When calling for a service inquiry or for troubleshooting assistance, be sure to have all of the following information on hand:

1. Equipment model number and serial number.
2. The actual AC input voltage.
3. The DC output voltage with and without the battery.
4. Result of the check of the AC and DC breakers.
5. The actual DC output current and voltage, measured with battery and load connected to charger.

**NOTE:** *When ordering replacement parts, drawings, or schematics, provide the model number, serial number, and description of problem, if available.*

La Marche Phone Number: (847) 299-1188  
24-hour **Emergency** Number: (847) 296-8939



### 7.3 Troubleshooting Chart



*Isolate from all power sources prior to performing any interior verifications or part replacements.*

Symptom	Possible Cause	Action
1  AC Breaker Trips	Incorrect AC Input Voltage	Measure AC voltage and verify against charger nameplate.
	AC Input Taps on Power Transformer Set Incorrectly	Verify tap settings using charger schematic or input table found on charger.
	AC-DC Short/AC-Ground Short/DC-Ground Short	Refer to Section 7.3.1.
	High DC Output Voltage	Refer to Symptom 4.
	Shorted Power Diodes/Diode Modules (SD1)	Refer to Section 7.3.3.
	High DC Voltage Shutdown Set Incorrectly	Refer to Section 4.1.2.
	Open Gate or Wire on Triac TR-1	Refer to Section 7.3.2.
2  DC Breaker Trips	Shorted Power Diodes/Diode Modules (SD1)	Refer to Section 7.3.3.
	Shorted Battery Cells or Customer Equipment	Remove all loads and batteries from A36D and confirm A36D functionality.
	Shorted Output Cables	Inspect DC cables for shorts.
	Defective Filtering Capacitors	Refer to Section 7.3.4.
	Loose Connections on DC Breaker	Inspect DC cable connections and assure proper insertion.
	Incorrect Battery Connected	Measure battery voltage and verify against charger nameplate.
3  Low Output Voltage or Current	No AC Input Voltage Applied	Measure and confirm input voltage.
	Incorrect Battery Connected	Measure battery voltage and verify against charger nameplate.
	Incorrect, Damaged or Loose Cable/Harness Connections	Visually inspect and verify all internal wiring using charger schematic.
	Incorrect Float/Equalize Voltage Settings	Refer to Section 4.1.1 for output adjustment instructions.
	Low Output Voltage Condition: charger is in Current Limit	Measure output current and verify against charger nameplate. If found to be in current limit, wait for batteries to charge or remove loads.
	Low Output Current Condition: Batteries are Fully Charged	Confirm by changing to Equalize mode; current should increase.
	Defective Power Diodes/Diode Modules/Triac	Refer to Section 7.3.3.
	Defective S2A-341S Control Board	Contact La Marche Service Department for further troubleshooting instructions.
	Defective Shunt	
	Defective Resonating Capacitor(s)	Refer to Section 7.3.4.
	Defective Batteries	Check battery cells.

4  High Output Voltage or Current	Incorrect, Damaged or Loose Cable/Harness Connections	Visually inspect and verify all internal wiring using charger schematic.
	Incorrect Battery Connected	Measure battery voltage and verify against charger nameplate.
	Incorrect Float/Equalize Voltage Settings	Refer to Section 4.1.1 for output adjustment instructions.
	Defective S2A-341S Control Board	Contact La Marche Service Department for further troubleshooting instructions.
	Defective Batteries	Check battery cells.
	Open Gate or Wire on Triac TR-1	Refer to Section 7.3.2.

### Ordering Replacement Parts

Contact La Marche to place an order for spare or replacement parts. To order replacement parts; please provide the model and serial number of the charger, the part needed, and the quantity required.

#### 7.3.1 Ground and Short Circuit Test

A simple ohmmeter check can be performed to check the charger for a short to ground, primary to secondary breakdown, AC-DC short, or DC ground. Before installation of a new charger, the above checks should be made before installing. If a short of this type is suspected on a charger in service, check as follows:

1. Disconnect AC input power to the charger. Disconnect the DC battery and loads from the charger.
2. Set ohmmeter scale on ohms scale RX100. Measure from one terminal of the input to one terminal of the output. Meter should not indicate. If the meter reads full scale deflection, this indicates an AC-DC short. During shipping, an AC wire may rub against the DC lugs, terminals, etc. and cause a short. These problems may be eliminated by being very careful in inspecting the wiring to assure the AC wires are not touching the DC wiring.
3. Check the input terminals to ground and check the output terminals ground. If the meter indicates full scale deflection, a wire is touching a metal part of the charger. Look for wires that are near any metal part and inspect for possible breakdown caused by shipping. The heatsink of the diodes and the control charger are insulated from ground through the mounting legs.

#### 7.3.2 Troubleshooting the Triac

On the ohmmeter, set the switches on "ohms", "DC", and "Rx10,000" scale. Disconnect the triac to be checked. Using an ohmmeter, measure the resistance between main terminals, MT1 and MT2 in both directions. A good device will indicate open circuit in both directions, a low resistance indicates a shorted device. Refer to figure on right.

Set ohmmeter to Rx100 scale. To check for a shorted triac gate lead, measure the resistance between gate (GATE) lead and main terminal MT1. A reading of zero ohms in both directions indicates a shorted gate. A reading of infinity in both directions indicates an open gate and the triac should be replaced. A good device should have resistance in both directions, but not zero ohms.

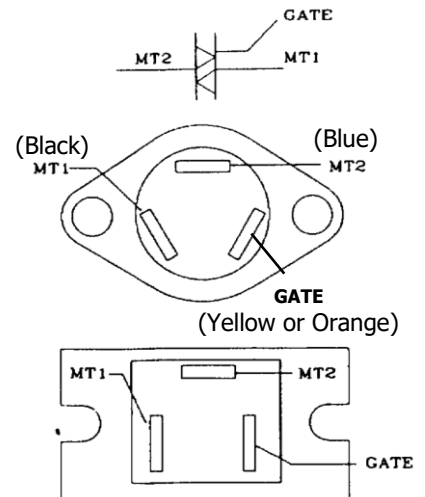

### 7.3.3 Troubleshooting and Replacing Power Silicon Diodes/Modules

1. On the ohmmeter, set the switches on "ohms", "DC", and "Rx100" scale and isolate one end of the diode by disconnecting the wires attached to the nipple (or pigtail) end of the diode (only one end of the diode must be disconnected). On a diode module, both of the outside leads must be disconnected.
2. Clip one lead of the ohmmeter to the anode lead of the diode. Clip the other ohmmeter lead to the cathode. Refer to figure on right.
3. Note the ohmmeter reading. Then reverse the leads to the diode. Again, note the ohmmeter reading. If the diode is good, the meter will indicate a high resistance in one direction and a low resistance with the leads reversed. If the diode is shorted, the meter will read full scale, or zero resistance with the leads in either direction. If the diode is "open", the ohmmeter needle will not indicate or it will show infinite resistance in either direction, indicating an open circuit.
4. All diodes must be checked in the event that more than one diode is defective.
5. If the diode is defective, remove the defective diode from the heatsink and replace with a new diode.

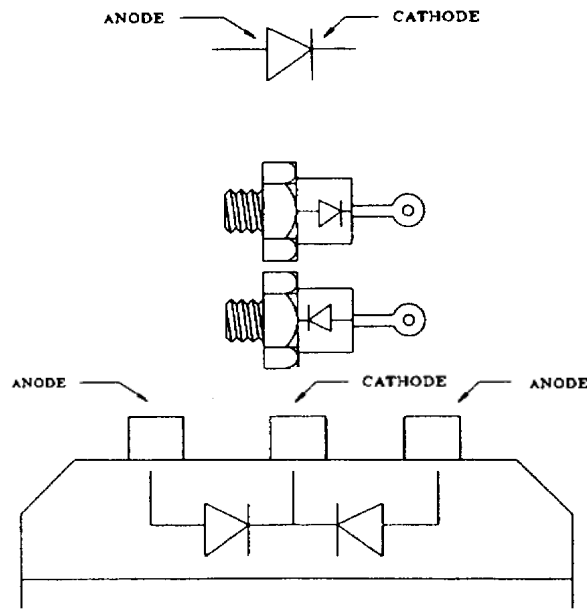

### 7.3.4 Checking Capacitors

1. When checking capacitors, assure all AC power is turned off and battery is disconnected from charger. Check capacitors with DC voltmeter to see that DC voltage is at near 0VDC.
2. Safely and momentarily short circuit the capacitor leads to assure complete discharge.
3. Connect the meter test leads to the capacitor leads or terminals and observe indicated resistance.
4. A good capacitor will indicate an initial low resistance and gradually increase as the capacitor charges. The final resistance of a good capacitor is usually several hundred thousand ohms approaching a megaohm.
5. Initial high resistance approaching infinity indicates an open capacitor. Initial and continued low resistance readings indicate a shorted capacitor.

**NOTE:** When ordering replacement parts, drawings, or schematics, always give model number, serial number and AC input voltage.

## Appendix A: A36D Specifications

<b><i>ELECTRICAL</i></b>	
<b>AC Input</b>	120, 208, 240, 380, or 480VAC Voltage range +10% / -12% Frequency Range 50Hz or 60Hz $\pm$ 5%
<b>DC Output</b>	10 - 400 ADC 12, 24, or 48VDC
<b>Output Filtering</b>	Single Phase - 30mV RMS, with or without battery
<b>Regulation</b>	$\pm$ 0.5% from no load to full load over the specified input voltage, frequency and ambient temperature range.
<b>Load Sharing</b>	When connected identical A36D chargers are forced to share the load equally (within $\pm$ 5%).
<b>Meters</b>	Digital Meter Display
<b><i>PROTECTION</i></b>	
<b>Current Walk-In</b>	The output current will gradually increase after the charger is turned on, eliminating surges and overshoot
<b>Current Limit</b>	50 - 115% of the rated DC output current.
<b>AC Breaker</b>	AC breaker is standard equipment. (2KAIC or 5KAIC depending on the model)
<b>DC Breaker</b>	DC breaker is standard equipment. (5KAIC, 7.5KAIC or 10KAIC depending on the model)
<b>Emergency Restoration</b>	The battery charger may be connected to a battery which is heavily discharged and recharge it without clearing any protective devices.
<b><i>ENVIROMENTAL</i></b>	
<b>Audible Noise</b>	Less than 65dBA at any point 5 feet from any vertical surface
<b>Operating Temperature</b>	32 to 122°F (0 to 50°C)
<b>Storage Temperature</b>	-40 to 185° F (-40 to 85° C)
<b>Relative Humidity</b>	0 to 95% (non-condensing)
<b>Cooling</b>	Convection cooled
<b>Shock</b>	The battery charger in its shipping container withstands shock developed when one edge of the container is dropped six inches while the opposite edge is resting on the ground, or it is dropped two inches without any physical damage or degradation of the electrical performance.
<b>Vibration</b>	The battery charger in its shipping contained, withstands vibration encountered in shipping without physical damage or degradation of the electrical performance.
<b>Altitude</b>	This battery charger is capable of operation at altitudes up to 10,000 feet at an ambient temperature of up to +40 degrees C.
<b>Ventilation</b>	The charger should be mounted so that ventilating openings are not blocked and air entering the cabinet does not exceed 50 degrees C (122 degrees F).

# Appendix B: A36D Menu Structure Flowchart

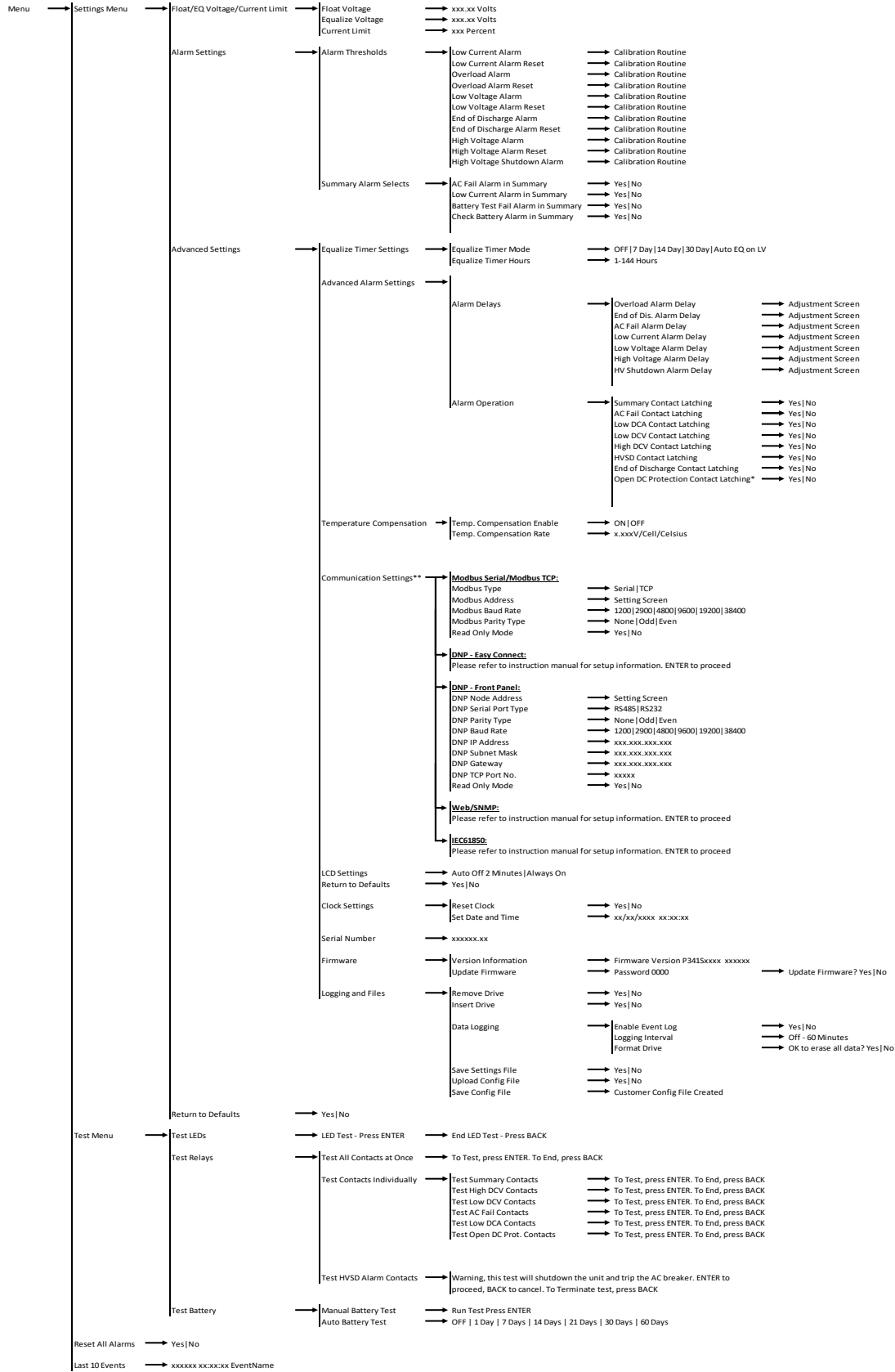

\*\*Submenu dependent on communications option included in charger

## Appendix C: microSD Card File Retrieval Instructions

The following instructions are for retrieving the files in the microSD card on an A36D charger via the Settings Menu. The instructions are as follow:

1. Press the "Menu" button to enter the Settings Menu and navigate through the following and select "YES" in the end to save the configuration file:

Settings Menu → Advanced Settings → Logging and Files → Save Config File

2. Press the back button as needed to return to the Logging and Files submenu.
3. Select "Save Settings File" and select "YES" in the end to save the settings file.
4. Press the back button to return to the Logging and Files submenu.
5. Select "Remove Drive" and select "YES" in order to properly remove the microSD card.
6. Open the door of the charger and locate the microSD card mounted in the S2A-341S display board (mounted to the door). Refer to figure below for microSD card location.
7. Safely remove the microSD card and using a microSD card reader and a computer, extract all the files from the microSD card.
8. Press the "Menu" button to enter the Settings Menu and navigate through the following and select "YES" in the end to safely reinstall the microSD card into the S2A-341S board microSD card slot:

Settings Menu → Advanced Settings → Logging and Files → Insert Drive

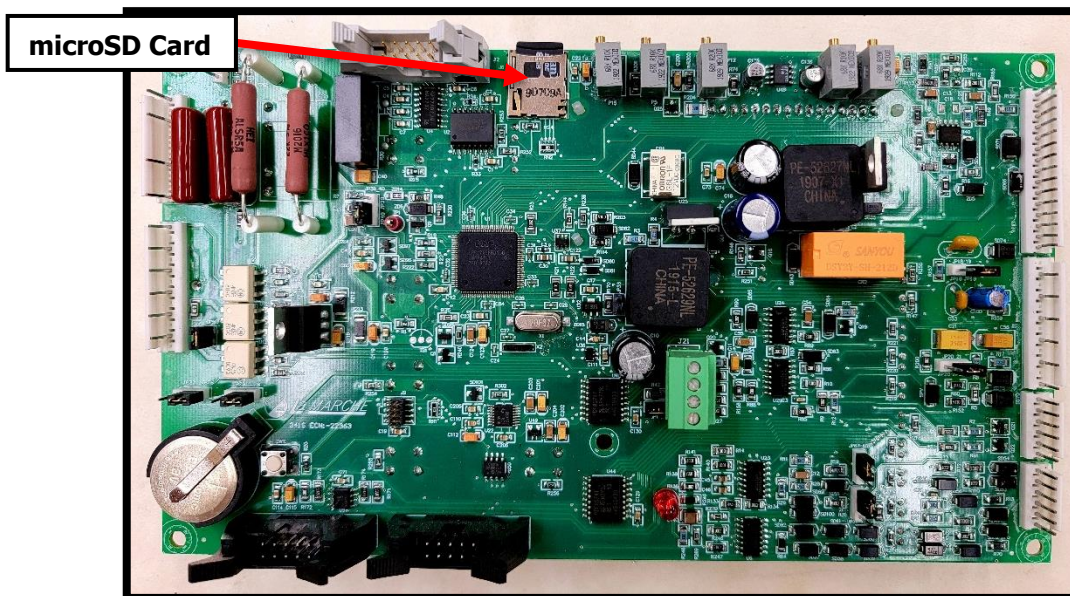

**Figure 17** – microSD Card Location (S2A-341S Display Board Rear View)

### Appendix D: A36D Current Draw and Feeder Breaker Sizes (Single Phase)

Single Phase						
Model Number	DC Amps	60 Hz			50 Hz	
		AC Current Draw (Recommended Feeder AC Supply Breaker)				
		A1 120V	ABD1 120/240/208V	BLD1 240/220/208V	5BL1 240/220V	
12 Volt Systems	A36D-15-12V	15	2.4 (5)	---	---	---
	A36D-20-12V	20	3.2 (7.5)	---	---	---
	A36D-25-12V	25	4.0 (7.5)	---	---	---
	A36D-30-12V	30	5.0 (10)	---	---	---
	A36D-50-12V	50	---	8.4/4.2/4.8 (20/10/10)	---	4.2/4.6 (10)
	A36D-75-12V	75	---	12.6/6.3/7.3 (30/15/15)	---	6.3/6.9 (15)
	A36D-100-12V	100	---	16.8/8.4/9.7 (30/15/15)	---	8.4/9.2 (15)
	A36D-150-12V	150	---	25.2/12.6/14.5 (30/15/15)	---	12.6/13.8 (15)
	A36D-200-12V	200	---	33.6/16.8/19.4 (40/20/20)	---	16.8/18.3 (20)
24 Volt Systems	A36D-10-24V	10	3.3 (5)	---	---	---
	A36D-12-24V	12	4 (7.5)	---	---	---
	A36D-15-24V	15	5 (7.5)	---	---	---
	A36D-20-24V	20	6.7 (10)	---	---	---
	A36D-25-24V	25	---	8.4/4.2/4.8 (15/7.5/7.5)	---	4.2/4.6 (7.5)
	A36D-30-24V	30	---	10/5/5.8 (15/7.5/7.5)	---	5/5.5 (7.5)
	A36D-50-24V	50	---	16.8/8.4/9.7 (30/15/15)	---	8.4/9.2 (15)
	A36D-75-24V	75	---	25.2/12.6/14.5 (40/20/20)	---	12.6/13.8 (20)
	A36D-100-24V	100	---	33.6/16.8/19.4 (40/20/20)	---	16.8/18.3 (20)
	A36D-150-24V	150	---	50.5/25.2/29.1 (70/35/35)	---	25.2/27.5 (35)
A36D-200-24V	200	---	67/33.6/38.8 (80/40/40)	---	33.6/36.7 (40)	
48 Volt Systems	A36D-10-48V	10	6.7 (10)	---	---	---
	A36D-12-48V	12	8 (15)	---	---	---
	A36D-15-48V	15	10 (15)	---	---	---
	A36D-20-48V	20	---	13.4/6.7/7.7 (15/7.5/7.5)	---	6.7/7.3 (7.5)
	A36D-25-48V	25	---	16.8/8.4/9.7 (30/15/15)	---	8.4/9.2 (15)
	A36D-30-48V	30	---	20/10/11.6 (30/15/15)	---	10.1/11 (15)
	A36D-50-48V	50	---	33.6/16.8/19.4 (50/25/25)	---	16.8/18.3 (25)
	A36D-75-48V	75	---	50.4/25.2/29.1 (70/35/35)	---	25.2/27.5 (35)
	A36D-100-48V	100	---	67.2/33.6/38.8 (80/40/40)	---	33.6/36.7 (40)
	A36D-150-48V	150	---	---	50.4/55/58.2 (70)	---
	A36D-200-48V	200	---	---	67.3/73.3/77.6 (80)	---

**Appendix E: A36D Current Draw and Feeder Breaker Sizes (Three Phase)**

<b>Three Phase</b>					
	<b>Model Number</b>	<b>DC Amps</b>	<b>60 Hz</b>		<b>50 Hz</b>
			<b>AC Current Draw (Recommended Feeder AC Supply Breaker)</b>		
			<b>BD3 (240/208V)</b>	<b>C3 (480V)</b>	<b>5G3 (380V)</b>
<b>24 Volt Systems</b>	A36D-200-24V	200	16.9/19.5 (25)	8.5 (15)	10.7 (15)
	A36D-300-24V	300	25.4/29.3 (35)	12.7 (20)	16 (20)
	A36D-400-24V	400	33.9/39.1 (50)	16.9 (25)	21.4 (25)
<b>48 Volt Systems</b>	A36D-200-48V	200	33.9/39.1 (50)	16.9 (25)	21.4 (25)
	A36D-300-48V	300	50.8/58.6 (80)	25.4 (40)	32.1 (40)
	A36D-400-48V	400	67.7/78.1 (100)	33.9 (50)	42.8 (50)



## Appendix F: A36D Heat Losses

**NOTE:** Based on 85% efficiency / 0.9 Power Factor at rated load.

	Model Number	Watts In	Watts Out	Watts Lost	BTU/Hr.
12 Volt Systems	A36D-15-12V	324	198	126	429
	A36D-20-12V	378	264	114	388
	A36D-25-12V	432	330	102	347
	A36D-30-12V	594	396	198	674
	A36D-50-12V	864	660	204	695
	A36D-75-12V	1296	990	306	1043
	A36D-100-12V	1680	1320	360	1227
	A36D-150-12V	288	1980	900	3068
	A36D-200-12V	2600	2624	960	3272
24 Volt Systems	A36D-10-24V	310	264	46	150
	A36D-12-24V	372	316	56	191
	A36D-15-24V	466	396	70	241
	A36D-20-24V	621	528	93	321
	A36D-25-24V	776	660	116	402
	A36D-30-24V	932	792	140	482
	A36D-50-24V	1553	1320	233	803
	A36D-75-24V	2329	1980	349	1205
	A36D-100-24V	3106	2640	466	1606
	A36D-150-24V	4659	3960	699	2410
	A36D-200-24V	6212	5280	932	3213
48 Volt Systems	A36D-10-48V	621	528	93	312
	A36D-12-48V	745	633	112	383
	A36D-15-48V	932	792	140	382
	A36D-20-48V	1242	1056	186	643
	A36D-25-48V	1553	1320	233	803
	A36D-30-48V	1864	1584	280	964
	A36D-50-48V	3106	2640	466	1606
	A36D-75-48V	4659	3960	699	2410
	A36D-100-48V	6212	5280	932	3213
	A36D-150-48V	9318	7920	1398	4819
	A36D-200-48V	12424	10560	1864	6426

## Appendix G: Document Control and Revision History

Part Number: 146100  
Instruction Number: P25-LA36DSERIES-3  
Issue ECN: 23307 – 12/22

<b>23316 – 01/23</b>	23307 – 12/22		