



La MARCHÉ

La Marche Manufacturing Company | www.lamarchemfg.com

ESCR V2

Engine Starting Battery Charger



Installation and Operation Manual

Important Safety Instructions

Before using this equipment read all manuals and other documents related to this unit and other equipment connected to this unit. Always have a copy of a unit's manual on file nearby, in a safe place; if a replacement copy of a manual is needed it can be found at www.lamarchemfg.com.

Electrical Safety



WARNING: Hazardous Voltages are present at the input of power systems. The output from chargers and from batteries may be low in voltage but can have a very high current capacity that may cause severe or even fatal injury.

When working with any live battery or power system, follow these precautions:

- Never work alone on any live power systems; someone should always be close enough to come to your aid.
- Remove personal metal items such as rings, bracelets, necklaces, and watches.
- Wear complete eye protection (with side shields) and clothing protection.
- Always wear gloves and use insulated hand tools.



WARNING: Lethal Voltages are present within the power system. Parts inside the unit may still be energized even when the unit has been disconnected from the AC input power. Check with a meter before proceeding. Do not touch any uninsulated parts.

- A licensed electrician should be used in the installation of any unit.
- Always disconnect the unit from the supply, batteries and loads before performing maintenance or cleaning.
- If the unit is hot-swappable, simply remove it from the shelf for any maintenance or cleaning.
- Always assume that an electrical connection is live and check the connection relative to ground.
- Be sure that neither liquids nor any wet material come in contact with any internal components.
- Do not operate this unit outside the input and output ratings listed on the unit nameplate.
- Do not use this unit for any purpose not described in the operation manual.

Mechanical Safety

- This unit or parts of the unit may get very hot during normal operation, use care when working nearby.
- Do not expose equipment to rain or snow. Always install in a clean, dry location.
- Do not operate equipment if it has received a sharp blow, been dropped, or otherwise damaged in any way.
- Do not disassemble this unit. Incorrect re-assembly may result in a risk of electric shock or fire.

Battery Safety



WARNING: Follow all of the battery manufacturer's safety recommendations when working with or around battery systems. DO NOT smoke or introduce a spark or open flame in the vicinity of a battery. Some batteries generate explosive gases during normal battery operation.

- To reduce risk of arc, connect and disconnect the battery only when the unit is off.
- If it is necessary to remove battery connections, always remove the grounded terminal from the battery first.
- Remove personal metal items such as rings, bracelets, necklaces, and watches.
- Always wear rubber gloves, safety glasses, and a rubber lined vest/apron when working near a battery.
- Have plenty of fresh water and soap nearby in case the battery electrolyte contacts skin, clothing, or eyes.
- If the battery electrolyte contacts skin or clothing, wash immediately with soap and water.
- If the electrolyte enters the eye, immediately flood the eye with running cold water for at least ten (10) minutes and seek medical attention immediately.
- Do not drop metal on a battery. A spark or short-circuit could occur and could cause an explosion.

Unit Location

- Allow at least 3 inches of free air on all vented surfaces (and external heatsinks) for proper cooling.
- Allow sufficient clearance to open the front panel for servicing.
- Do not operate this unit in a closed-in area or restrict ventilation in any way.
- Do not set any battery on top of this unit.
- Never allow battery electrolyte to drip on this unit when reading the specific gravity or filling the battery.
- Never place this unit directly above a standard flooded battery. Gases from the battery will corrode and damage equipment.
- A sealed maintenance free or valve regulated lead acid (VRLA) battery may be placed below this equipment.

Check for Damages

Prior to unpacking the product, note any damage to the shipping container. Unpack the product and inspect the exterior of product for damage. If any damage is observed, contact the carrier immediately. Contact La Marche for advice on the risk due to any damage before installing the product. Verify that you have all the necessary parts per your order for proper assembly.



CAUTION: Failure to properly file a claim for shipping damages, or provide a copy of the claim to La Marche, may void warranty service for any physical damages reported for repair.

Returns for Service

Save the original shipping container. If the product needs to be returned for service, it should be packaged in its original shipping container. If the original container is damaged/unavailable, make sure the product is packed with at least three inches of shock-absorbing material to prevent shipping damage. *La Marche is not responsible for damage caused by improper packaging of returned products.*

Inspection Checklist

- Enclosure exterior is not marred or dented.
- There are no visibly damaged components.
- All hardware and connections are tight.
- All wire terminations are secure.
- All items on packing list have been included.

Handling

Equipment can be very heavy and/or top heavy. Use adequate manpower or equipment for handling. Until the equipment is securely mounted, care must be used to prevent the equipment from being accidentally tipped over.

Table of Contents

Important Safety Instructions	i
Electrical Safety	i
Mechanical Safety	i
Battery Safety	i
Unit Location	ii
Check for Damages	ii
Returns for Service	ii
Inspection Checklist	ii
Handling	ii
Table of Contents	iii
General Description	1
Understanding the Model Number	1
Optional Accessories Included in the Unit	1
Quick Start Guide	2
Configuration Mode Adjustment	3
1 Installation	4
1.1 Mounting the ESCR	4
1.2.1 AC Input Connections	6
1.2.2 Output Connections	6
1.2.3 Power Cabling Guide	7
1.2.4 Standard Alarms	8
1.2.5 External Temperature Compensation (Option 11W/11Y)	10
2 Operation	12
2.1 Starting the ESCR	12
2.1.1 Checking the Installation	12
2.1.2 Starting/Stopping the ESCR	12
2.1.3 Start-Up Sequence	12
2.2 The Front Panel Display	13
2.2.1 Controls	13
2.3 Selecting the Charging Mode	14
2.4 Configure Mode	14
2.4.1 Basic Settings	14
2.5 ESCR Customer Configuration Menu Structure	16
3 Service	17
3.1 Performing Routine Maintenance	17
3.2 Troubleshooting Procedure	18
3.3 Troubleshooting Chart	19
Appendix A: ESCR Specifications	20
Appendix B: Manufacturer's Warranty	22

Appendix C: Document Control and Revision History23

General Description

The ESCR engine starting battery charger product line utilizes microprocessor-controlled SCR Charging Technology. The PWM control provides the highest reliability that is required for maintaining and recharging engine start batteries for generator sets. This charger is suitable for various types of batteries such as flooded lead acid, VRLA and NiCad.

Automatic input sensing for 120/208-240 VAC 50/60Hz, if applicable, does not require any tap changes. The multi-output configuration capability, if applicable, makes this product line flexible and convenient for multiple jobs. The 0.5% regulation, temperature compensation, battery check, equalize timer, along with adjustable output voltage and current limiting assures longevity and performance for your batteries. This economical solution equipped with advanced features incorporates La Marche quality and reliability.

Understanding the Model Number

The ESCR model number is coded to describe the charger and the options that are included. Find the model number on the nomenclature nameplate of the charger. Then, follow the chart to determine the configuration of your battery charger.

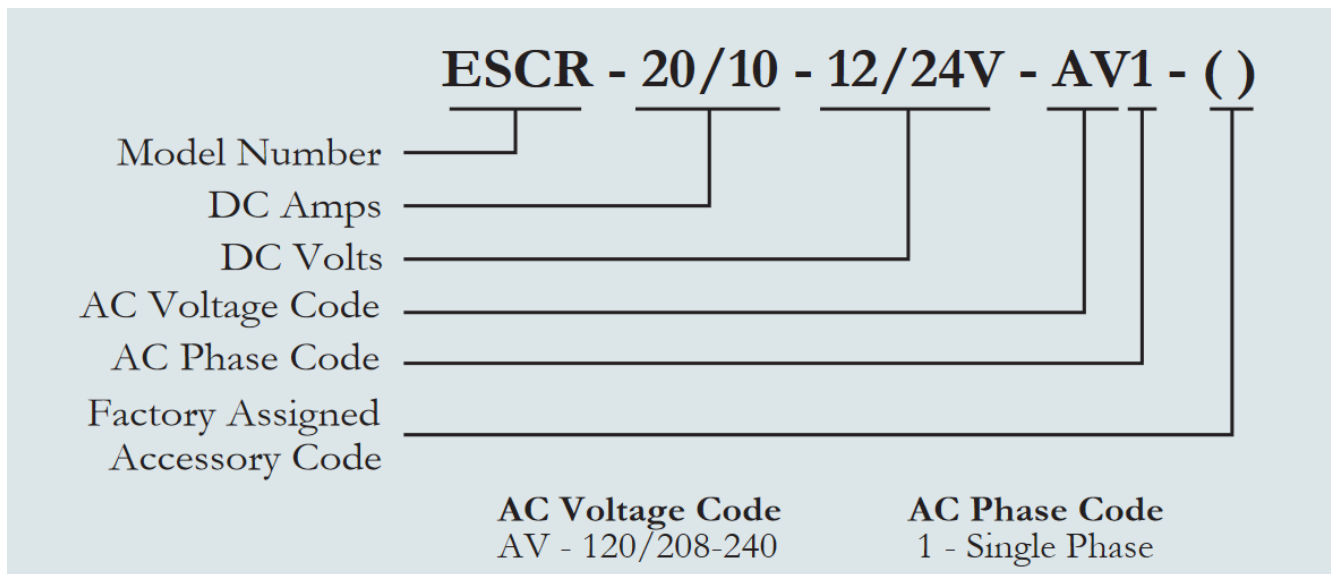

Optional Accessories Included in the Unit

This unit may have been outfitted with a number of optional accessories or option packages. To find out what options this unit has (if any), refer to the very first page of the manual package.

La Marche ESCR Engine Starting Battery Charger: Getting started

WARNING: Please read the Important Safety Instructions before proceeding.
Make Sure to check for any shipping damages before getting started.

1 Remove Bottom Panel

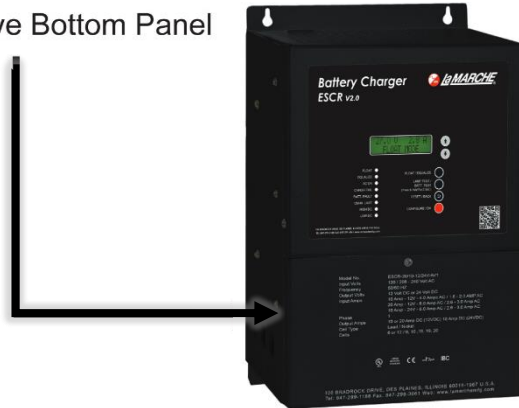

2 Connect proper AC. Battery does not need to be connected during configuration mode.

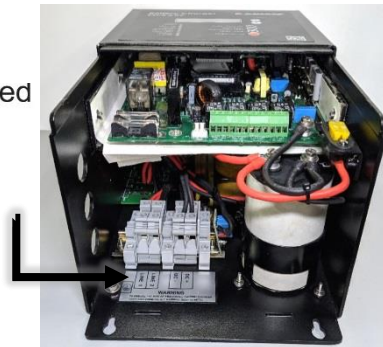

3 To change setting, you must enter the configuration mode by pressing the CONFIG/OK red button located on the front panel. The unit does not supply output in the configuration mode.

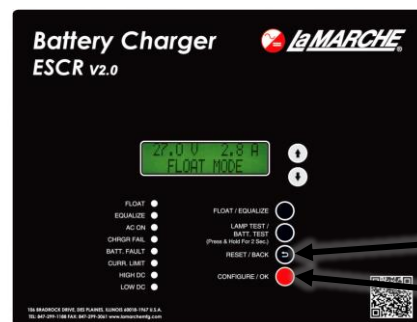

Reset Button
OK Button

Factory Default Settings

- Cell Type
 - 6 Lead Acid (12VDC Mode)
 - 12 Lead Acid (24VDC Mode)
 - 16 Lead Acid (32VDC Mode)
- Float Voltage
 - 2.25 Volts per Cell
- Equalize Voltage
 - 2.33 Volts per Cell
- Equalize Timer
 - 8-hour Equalize Timer
 - Manual Equalize Cycle
- Current Limit
 - 105%
- Temperature Compensation
 - Disabled
- Alarm Setting
 - Alarm Delay - 5 Seconds
 - Low VDC - 1.98 Volts per Cell
 - High VDC - 2.45 Volts per Cell
 - High VDC Shutdown - 2.50 Volts per Cell
 - Low DC Current - 0.5 Amps

La Marche Mfg. (A U.S. Company)
106 Bradrock Drive, Des Plaines, IL 60018
Tel: 847.299.1188 Fax: 847.299.3061
sales@lamarchemfg.com
www.lamarchemfg.com

Configuration Mode Adjustment

Use the up/down arrows to browse the selections. The asterisk next to the selection denotes the selected mode. CONFIG/OK button is used as save or enter key and the RESET/BACK button is used as cancel or step back in the menu.

Basic Output

- DC Output Voltage and Current (if applicable)
- Number of Cells



Float Voltage

- Adjustable Volts/Cell using the Up and Down arrows

Equalize Voltage

- Adjustable Volts/Cell using the Up and Down arrows



Equalize Timer

- Equalize Hours
- Equalize Cycle

Current Limit

- Adjusted using Up and Down arrows

Temperature Compensation

- Selectable Enable or Disable



Battery Test

- Selectable Auto or Manual Battery Test

Alarm Settings

- Alarm Delay
 - Common Delay
 - High DC Shutdown Delay
- Low DC Voltage
- High DC Voltage
- High DC Shutdown
- Low DC Current
- AC Failure



Factory Settings

- Restore all alarms to default values.
- Basic output settings of charger do not change.

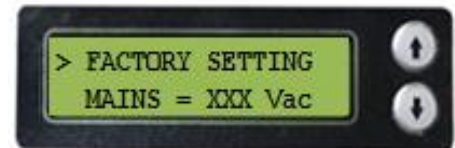

Mains Voltage

- Displays AC voltage at input terminals.

- 4 Turn unit OFF and connect battery to POS and NEG terminals.

1 Installation

1.1 Mounting the ESCR

Install the charger so that the flow of air through the ventilators is not obstructed.

Model Number	DC Output		AC Input		Overall Dimensions W x D x H	Case No.	Shipping Weight	
	Volts (Nominal)	Amps	Volts (Nominal)	Amps			lbs	kg
ESCR-6-12/24V-AV1*	12 24	6	120/208-240	3.0/1.5	6.4" x 7" x 9.35" 162 x 179 x 237mm	100	16	7
ESCR-10-24V-AV1	24	10	120/208-240	6.0/3.0	7.75" x 7" x 11.25" 197 x 179 x 285mm	98	25	11
ESCR-20/10-12/24V-AV1	12 12 24	10 20 10	120/208-240	3.2/1.6 5.4/3.0 6.0/3.0	7.75" x 7" x 11.25" 197 x 179 x 285mm	98	25	11
ESCR-20-24V-AV1	24	20	120/208-240	12.1/6.1	11.38" x 9" x 15" 289 x 229 x 381mm	99	42	19
ESCR-40/20-12/24V-AV1	12 24	40 20	120/208-240	10.9/5.9 12.1/6.1	11.38" x 9" x 15" 289 x 229 x 381mm	99	42	19
ESCR-10-32V-AV1*	32	10	120/208-240	7.0/3.5	7.75" x 7" x 11.25" 197 x 179 x 285mm	98	25	11
ESCR-20-32V-AV1*	32	20	120/208-240	14.0/7.0	11.38" x 9" x 15" 289 x 229 x 381mm	99	42	19

Table 1 - ESCR Weights and Dimensions

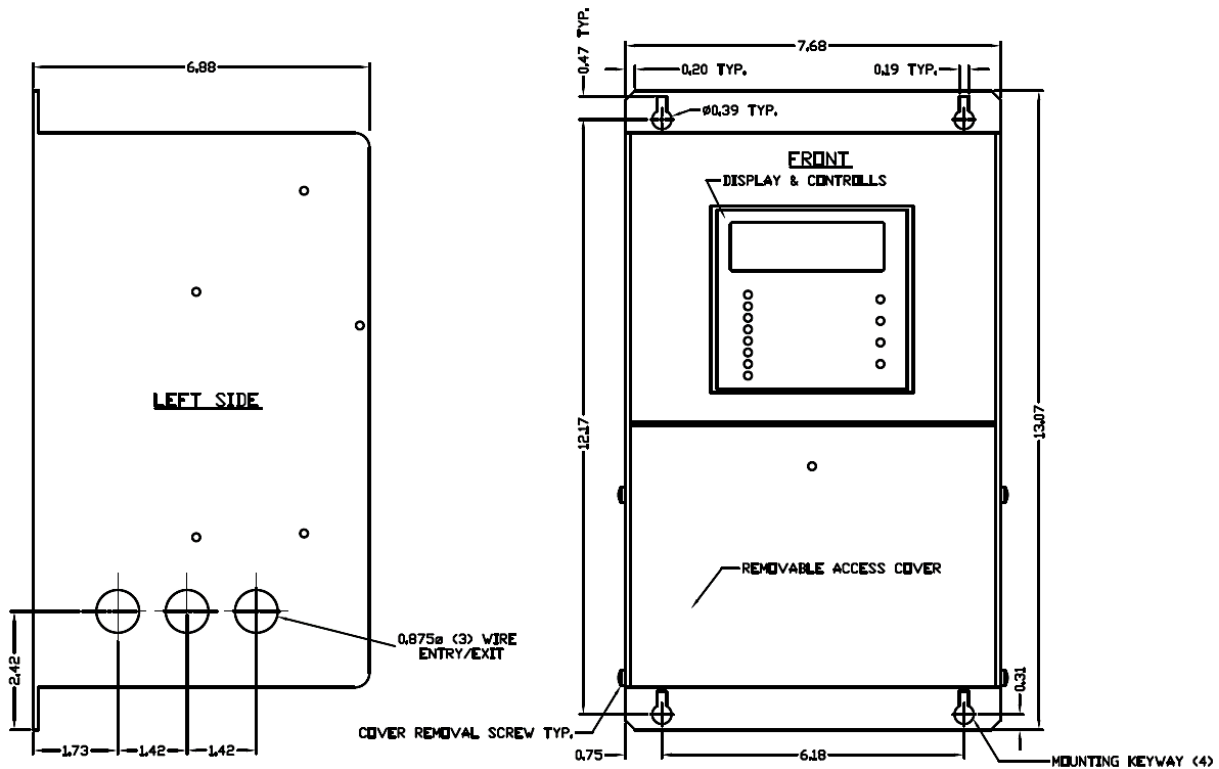

Figure 1 - ESCR Mounting Dimensions for D98

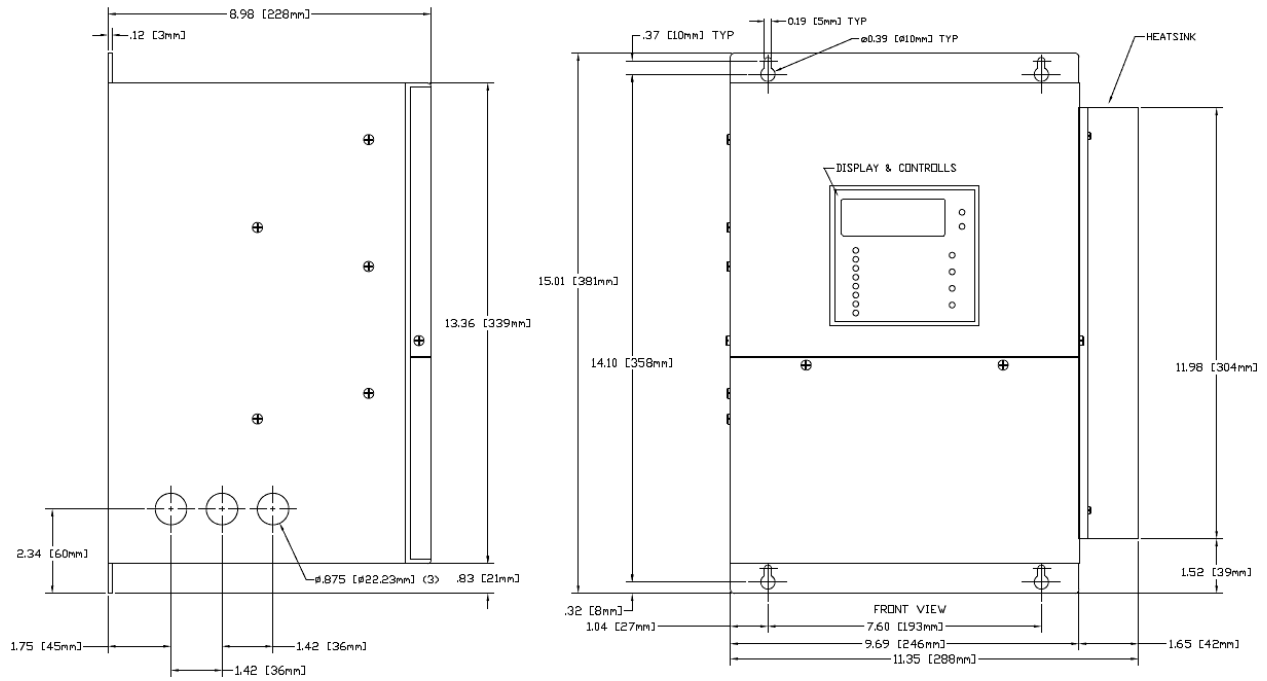

Figure 2 - ESCR Mounting Dimensions for D99

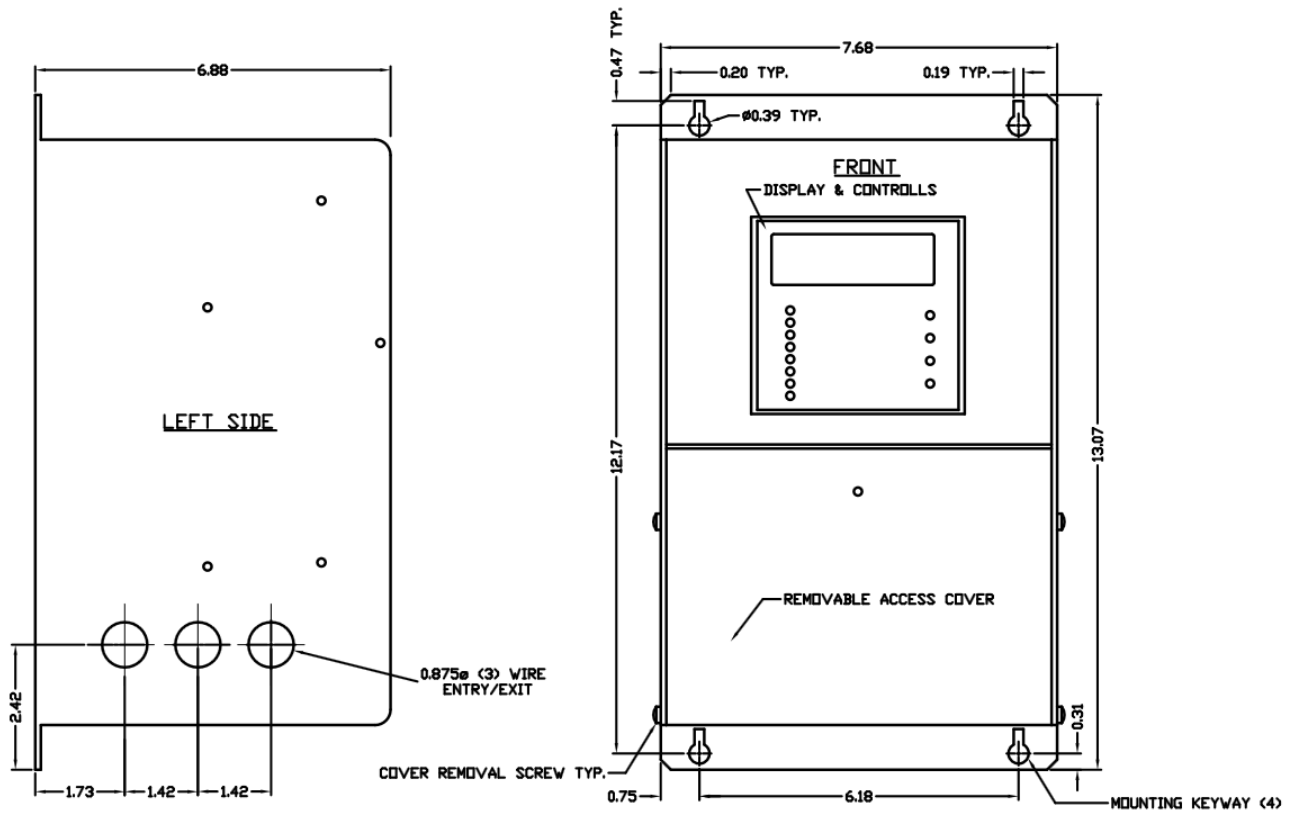

Figure 3 - ESCR Mounting Dimensions for D100

1.2 Electrical Connections

1.2.1 AC Input Connections

Before beginning any work inside the charger enclosure, ensure that all incoming AC supply and DC load wires are de-energized. Verify that no voltage is present inside the case by using a voltmeter at all input and output terminals. Check that the source voltage and frequency match the charger front nameplate specifications. Select wire size, using Table 2.

NOTE: Feeder breaker should be sized to match the size of the AC protection used in charger.

Breaker Size (Amps)	AWG Minimum Wire Size Requirement for Customer Connection	AWG Minimum Wire Size for Equipment Grounding
5	#14	#14
10	#14	#14
15	#12	#12
20	#12	#12
25	#10	#12
30	#10	#10
35	# 8	#10
40	# 8	#10
45	# 8	#10
50	# 8	#10
60	# 6	#10

Table 2 – Wire Sizing

NOTE: These are recommended sizes. All National and Local Wiring Codes must be followed.

1.2.2 Output Connections

Before connecting the Battery and/or DC loads, it is recommended to apply AC power and set the configuration for the correct output. See section 2.3 for the configuration instructions. Once the configuration is set, remove AC power from the main feeder breaker to the charger.

Select proper size for the DC wiring from Table 2. If the distance between the unit's DC output and the DC load exceeds 10 feet, use the Power Cable Guide below to minimize the voltage drop across the wire distance.



Figure 4 – ESCR Connections

1.2.3 Power Cabling Guide

Use the following formulas and table to determine proper wire size for minimal voltage drop.

Table of Conventions

- CMA = Cross section of wire in circular MIL area
- A = Ultimate drain in amperes
- LF = Conductor loop feet
- MaxAmp = Maximum allowable amperes for given voltage drop
- AVD = Allowable voltage drop
- K = 11.1 for commercial (TW) copper wire (KS5482-01)
- = 7.4 for aluminum (KS20189)

Calculating Wire Size Requirements

$$CMA = \frac{A \times LF \times K}{AVD}$$

Calculating Current Carrying Capacity of Wire

$$MaxAmp = \frac{CMA \times AVD}{LF \times K}$$



CAUTION: Observe proper polarity when connecting the battery cables to the charger's DC output terminals.

SIZE (AWG)	AREA CIR.MILS	SIZE (AWG)	AREA CIR.MILS
18	1620	6	26240
16	2580	4	41740
14	4110	3	52620
12	6530	2	66360
10	10380	1	83690
8	16510	0	105600

Table 3 - Wire Size/Area

1.2.4 Standard Alarms

Various alarms are included as a standard feature of the ESCR. Only the following alarms include a set of form 'C' contacts: High DC Voltage, Low DC Voltage, Charger Failure, and AC Failure. Having contacts available enables the user to connect remote annunciators. The alarm contacts are rated for 10 Amps at 28VDC. Refer to Figures 5 & 6 for alarm contact connections.

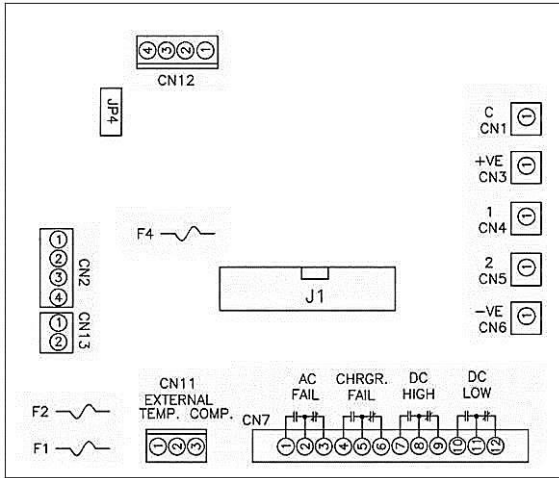

Figure 5 – S2A-349 Control/Alarm Board

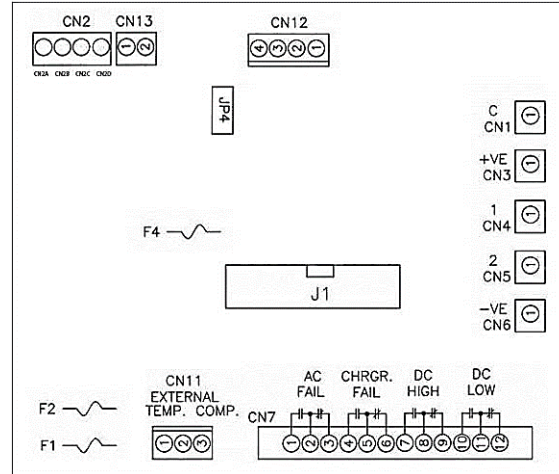

Figure 6 – S2A-357 Control/Alarm Board

LED indicators are provided for the following alarms: AC Fail, Charger Fail, Battery Fault, Current Limit, High DC Voltage, and Low DC Voltage. Refer to Figure 7 below.

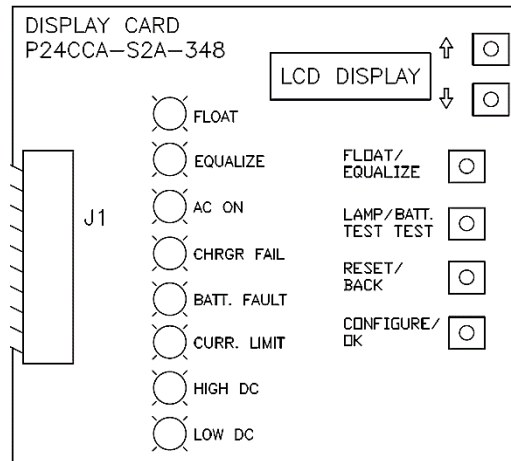

Figure 7 – S2A-348 Display Board

Alarm Connections

Before making any connections to the ESCR, ensure that the AC power is off at the main breaker box. Disconnect the battery from the charger via the battery disconnect breaker or manually disconnecting the battery cables. Verify no voltage is present by using a voltmeter at all input and output terminals.

For Charger Fail, AC Fail, and Low DC Voltage alarm, if it is desired that the annunciator be active until the alarm triggers, connect the annunciator leads to the **NO** and **C** contacts of the desired alarm (located on the control board). If it is desired that the annunciator be activated when an alarm triggers, connect the annunciator leads to the **NC** and **C** contacts of the desired alarm.

For High DC Voltage alarm, if it is desired that the annunciator be active until the alarm triggers, connect the annunciator leads to the **NC** and **C** contacts of the desired alarm (located on the control board). If it is desired that the annunciator be activated when an alarm triggers, connect the annunciator leads to the **NO** and **C** contacts of the desired alarm.

Example for AC Fail Alarm Connections:

A customer wants a Green Lamp to be illuminated while the AC power is on, and a Speaker to sound when the AC is lost. Using customer provided equipment, they could connect an external power supply, a speaker, and a green lamp. The lamp would be connected to Pin 1 (**NO** contact) and the low side of the power supply. The speaker would be connected to Pin 3 (**NC** contact) and the low side of the power supply. The high side of the power supply would be connected to Pin 2 (**C** contact). See Figure 8.

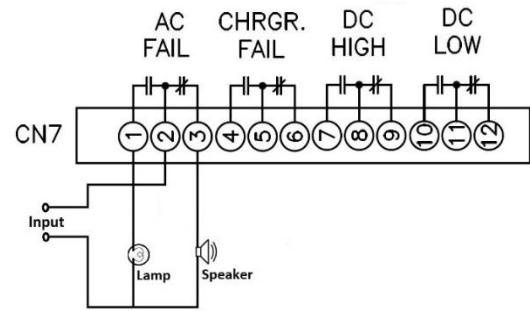

Figure 8 - Example Connections (Customer Provided Equipment)

The **Charger Failure Alarm** occurs if the charger is not able to regulate the output voltage. This is a latching alarm. Alarm will not clear until the charger is reset by pressing the Reset button.

The **AC Failure Alarm** will trigger and the green "AC ON" LED will turn off, after the preset delay, when the AC power to the charger is lost. The AC Failure alarm functions as a fail-safe relay alarm; the relay will de-energize on failure condition. The alarm will automatically reset when AC power is restored to the unit. When AC power is lost, the front panel display and indicators will remain powered by the connected batteries. Refer to the example for AC Fail alarm connections on Figure 8.

NOTE: The alarm contacts for AC Fail alarm displayed in Figure 5 and Figure 6 are shown in de-energized state.

The **High DC Voltage Alarm** will trigger and the red "HIGH DC" LED will turn on, after the preset delay, if the DC output voltage of the charger rises above the specified alarm threshold. The alarm will clear when the DC output voltage returns to normal.

The **High DC Shutdown Alarm** will trigger and the red "HIGH DC" LED will turn on, after the preset delay, if the DC output voltage of the charger rises above the specified alarm threshold and there is load on the charger. The display will read "HIGH DC SHUTDOWN" the charger output will shut off, and the alarm will latch. To clear the alarm, press the Configure/OK button on the front panel once the DC output voltage is below the alarm threshold.

NOTE: The High DC Shutdown alarm will not trigger if there is a Low DC Current alarm present.

The **Low DC Voltage Alarm** will trigger and the red "LOW DC" LED will turn on, after the preset delay, when the DC output voltage of the charger falls below the specified alarm threshold. The alarm will clear when the DC output voltage returns to normal.

During engine cranking, the **Battery Fault Alarm** will trigger and the "LOW DC" and "BATT. FAULT" LED will turn on, causing the charger output to be disabled for 100 seconds. The messages "BATTERY FAULT" and "PUSH OK TO CLEAR" will appear on the LCD screen. The DC LOW relay contacts will be triggered per Battery Fault condition. This is a latching alarm. To reset the alarm, press the Configure/OK button on the front panel or let it time out. After 100 seconds, the output voltage will ramp up slowly and return to normal level. The ramp up may be manually restarted before the 100 seconds by pressing the Configure/OK button.

The **Low DC Current Alarm** will trigger, after the preset delay, when the DC current of the charger falls below the specified alarm threshold and will reset when the DC current rises above the threshold. This alarm could be normal if no constant loads are connected to the output of the charger or if the battery is fully charged.

The **Current Limit Alarm** LED will turn on when the DC current of the charger rises above the specified alarm threshold and will clear when the DC current lowers below the threshold.

Alarm	Logic
AC Fail	De-Energize on Failure
Charger Fail	De-Energize on Failure
High DC Voltage	Energize on Failure
Low DC Voltage	De-Energize on Failure

Table 4 – Alarm Relay Logic

1.2.5 External Temperature Compensation (Option 11W/11Y)

The natural voltage of a battery changes as a function of temperature change. As the battery temperature rises, the effective voltage of the battery decreases. Without Temperature Compensation, the battery charger will always produce a set constant output voltage. As the battery temperature increases, this constant voltage will then induce a higher output current from the charger. This higher current can result in overcharging the battery, which in turn can result in damage to the batteries.

Temperature Compensation combats this overcharging by adjusting the charger's output voltage based on the temperature read by the temperature probe. In order to increase the accuracy of the temperature compensation the external probe can be used to measure the temperature of the battery.

Option 11W includes the compensation circuit and a 24-foot-long temperature probe. Option 11Y includes the compensation circuit and a 100-foot-long temperature probe. With either option, approximately one foot of the probe is taken inside the charger enclosure.

External Probe Connection Procedure

Before making any connections to the ESCR, ensure the AC power is off at the main breaker box. Disconnect the battery from the charger via the battery disconnect breaker or manually disconnecting the battery cables. Verify no voltage is present by using a voltmeter at all input and output terminals.

To connect the external probe, **JP4** jumper (located on the control board) must be removed. Removing this jumper will disable the charger's internal temperature compensation.

After removal of JP4, the external probe can be connected to the CN11 terminal on the control board. Install the probe lug to the battery. As battery setups vary between customers and battery manufacturers, it is recommended that the battery manufacturer be consulted for optimal placement of the probe. The probe is completely isolated from the compensation circuitry, so the battery voltage will not affect the compensation.

With the probe connected, enter Configuration Mode and assure Temperature Compensation has been enabled. For further details, refer to section 2.3.



Figure 9 - Temperature Probe Connection

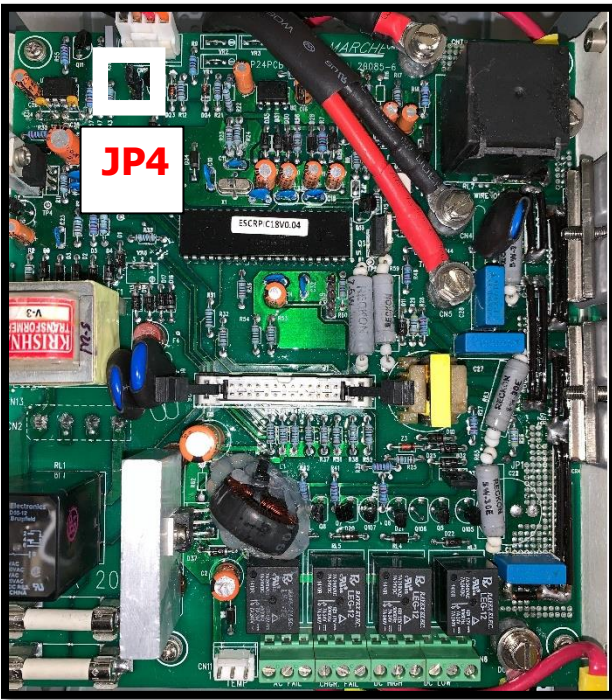

**Figure 10 - S2A-349
20A ESCR Control Board Top View**

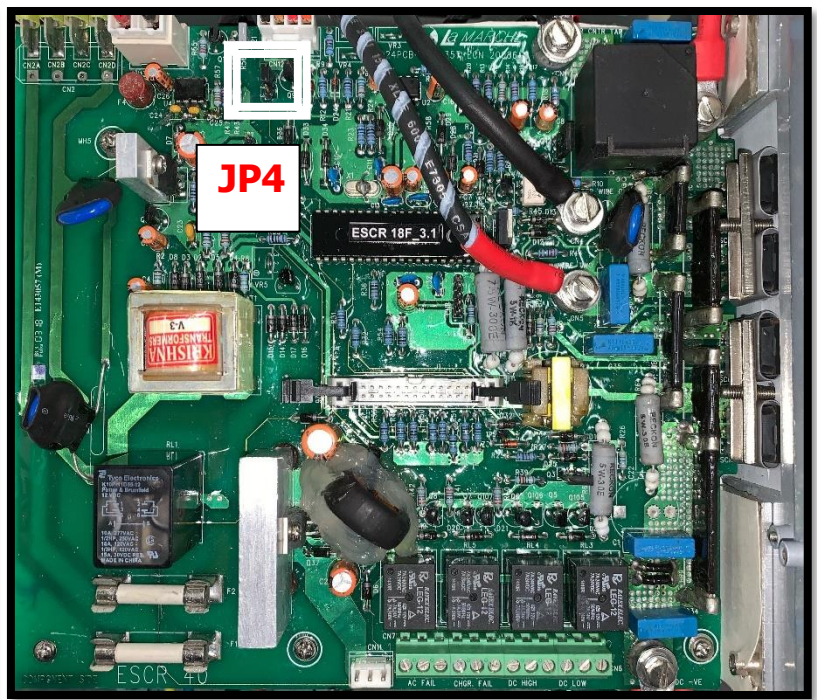

**Figure 11 - S2A-357
40A ESCR Control Board Top View**

- When an external probe is to be used for temperature compensation, internal temperature compensation must be disabled on the ESCR control circuit board assembly.
- To disable internal temperature compensation, remove the JP4 jumper.
- To enable internal temperature compensation, install JP4 jumper across pins 2 and 3.

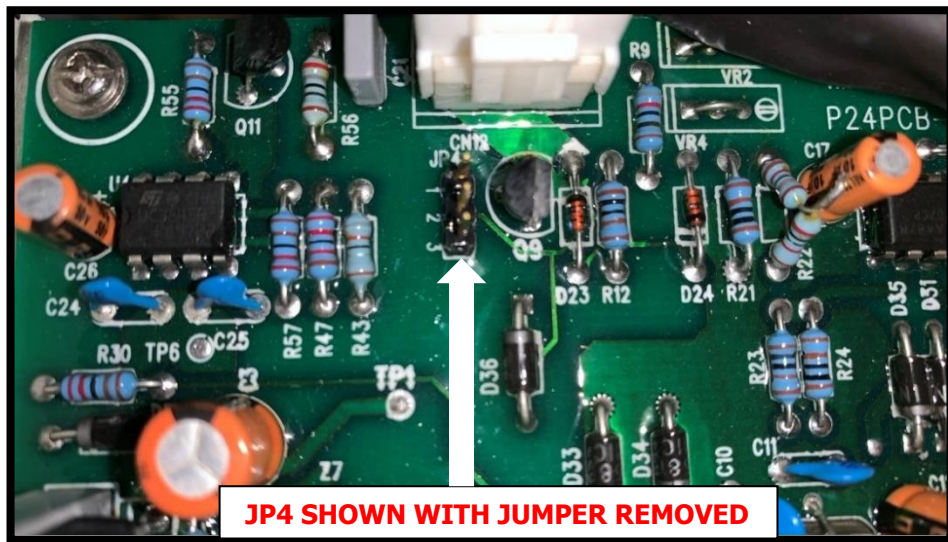

Figure 12 - S2A-349 20A ESCR Control Board JP4 Location

2 Operation

2.1 Starting the ESCR



All equipment is shipped from the factory fully tested and adjusted based on the factory settings listed below. Before connecting the battery, verify the recommended voltage settings with the battery manufacturer and adjust the output settings accordingly. Failure to match the charger settings with the connected battery may damage or shorten the life of the battery.

Factory Settings

The adjustable factory settings of the ESCR are based on the model number, unless otherwise specified. All chargers are set at the factory with the following settings:

Parameter	Lead Acid / VRLA	Nickel Cadmium	Delay (sec.)
Float Voltage	2.25 V/C	1.40 V/C	
Equalize Voltage	2.33 V/C	1.55 V/C	
Low DC Voltage	1.98 V/C	1.20 V/C	5
Low DC Current	0.5 Amps		5
Current Limit	105% of nominal output current		
High DC Voltage	2.45 V/C	1.61 V/C	5
High Voltage Shutdown	2.50 V/C	1.65 V/C	25
AC Failure	90 VAC / 180 VAC		5
Equalize Timer Mode	Manual		
Equalize Time	8 Hours		

Table 5 – Factory Default Values

NOTE: V/C – Volts per Cell, LA – Lead Acid, VRLA – Valve Regulated Lead Acid, NC – Nickel Cadmium

2.1.1 Checking the Installation

Before starting the ESCR, verify that all connections are correct, and all terminations are securely tightened. Verify the input voltage, frequency, and output voltage is correct per application against the nameplate ratings of the charger.

2.1.2 Starting/Stopping the ESCR

Once proper connections are established, energize the charger by applying AC input voltage. This will charge the capacitors inside the unit and eliminate heavy arcing when the batteries are connected. Shut down the charger by removing AC input voltage, then the batteries.

2.1.3 Start-Up Sequence

Upon powering up the ESCR, the LCD will display the model and software number.

2.2 The Front Panel Display

After the ESCR has completed start up, the "AC ON" LED on the front panel and either the "FLOAT" or "EQUALIZE" LED on the front panel will be lit. The LCD will display the system DC output voltage and DC output current on line one. Line two of the LCD displays the status of ESCR.

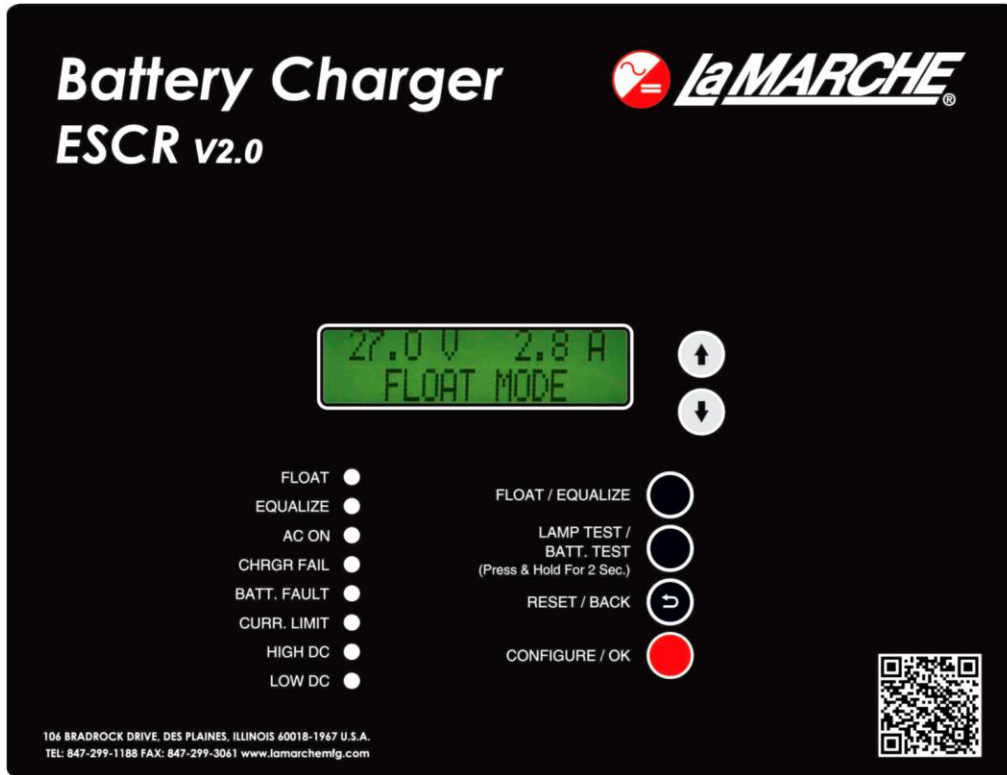

Figure 13 - Front Panel Display (Unit in Float Mode)

2.2.1 Controls

Up/Down Arrows – The Up and Down arrows offer no function outside of Configure Mode. When in Configure Mode the up and down arrows allow the customer to navigate menus and increase or decrease values.

Float/Equalize Button – The Float/Equalize Button allows the user to manually switch between float mode and equalize mode. When the ESCR is in equalize mode, line two of the display will switch between "EQUALIZE MODE" and the time remaining.

Lamp Test/Battery Test Button – The Lamp Test/Battery Test button allows the user to check the function of all of the Front Panel LEDs without affecting the operation of the charger. While the lamp test is running all of the LED's flash and a sequence of numbers is written to the display. It also allows the charger to perform a battery test.

Reset/Back Button – Under normal system operation, the Reset/Back Button operates as the reset button. Pressing reset allows the user to restart the ESCR. Upon restarting, the ESCR will once again go through the start-up sequence describe in section 2.1.3. In the Configure mode the Reset/Back button operates as the back button. Pressing the back button allows the user to navigate to a previous screen or out of the configuration.

Configure/OK Button – In Configure Mode, the charger is turned off, and there will be no output. The Configure/OK button brings the ESCR into Configuration Mode, allowing the user to set charger parameters in Basic Settings as well as Float Voltage, Equalize Voltage, Equalize Timer, Current Limit, Temperature Compensation and Alarm settings. Once in Configuration Mode, this button becomes the OK button which is used to make selections within the menus.

2.3 Selecting the Charging Mode

The ESCR has two different settings for DC output voltage, Float Mode and Equalize Mode. Float charging mode is used for all normal battery charging needs. In the case of the ESCR, the Float Mode can also be used for battery elimination (directly powering the DC load from the ESCR). Equalize Mode is used when it is necessary to Equalize (or balance) the level of charge across all cells present in the battery. Consult the battery manufacturer for the proper Equalize procedures. Refer to Section 2.4.2 and 2.4.3 for Float and Equalize voltage adjustments.

There are two LEDs on the front panel that indicate the current mode of the charger; the green LED indicates Float mode, and the amber LED indicates Equalize mode. If the charger is in Float Mode, simply press the Float/Equalize button to switch into Equalize Mode. If the charger is in Equalize Mode, it will automatically switch back to Float Mode after the designated Equalize time. Alternatively, the charger can manually be switched to Float Mode by pressing the Float/Equalize button again.

2.4 Configure Mode

Pressing the Configure/OK button enters Configure Mode. In Configure Mode, the charger is turned off, and there will be no output.



CAUTION: There will be no output from the charger while in the Configure Mode. Caution must be taken when powering critical loads.

Each of the adjustable settings of the ESCR is accessible using Configure Mode. Once in Configure Mode, the user can navigate using the Up and Down arrows to the right of the display, the Reset/Back button, and the Configure/OK button.

The following features are available to be configured:

2.4.1 Basic Settings – Allows selection of the output configuration (voltage/current, if applicable) and the number of cells.

1. Select BASIC OUTPUT
 - Select "OUTPUT V AND I" (Output Voltage and Current)
 - Select the charger configuration needed
 - Return to previous menu by pressing "RESET / BACK" button
 - Select "NO. OF CELLS"
 - Select the number and type of battery cells to be charged
 - Return to configuration menu by pressing the "RESET / BACK" button

2.4.2 Float Voltage – Allows the selection of voltage per cell for Float operation.

1. Select FLOAT VOLTAGE from configuration menu
 - Set to the voltage recommended by battery manufacturer

2.4.3 Equalize Voltage – Allows the selection of voltage per cell for Equalize operation.

1. Select EQUALIZE VOLTAGE from configuration menu
 - Set to the voltage recommended by battery manufacturer.

2.4.4 Equalize Timer – Allows selection for the length of the Equalize cycle (in hours) as well as when an Equalize cycle is initiated (manual/automatic).

1. Select EQUALIZE TIMER from configuration menu
 - Select EQUALIZE HOURS
 - Set the hours that the charger will be in the EQUALIZE mode.
 - Select EQUALIZE MODE and set for MANUAL or one of the automatic modes:
 - Manual:* Equalize cycle is started manually
 - 7 Days:* Equalize cycle is started automatically every 7 days
 - 14 Days:* Equalize cycle is started automatically every 14 days
 - 30 Days:* Equalize cycle is started automatically every 30 days
 - Auto-AC Fail:* Equalize cycle starts automatically when AC input power is restored after a power failure (AC power must be off for 5 minutes for this mode to be activated)
 - Auto-DC Low:* Equalize cycle starts automatically if battery voltage falls below the Low Voltage Alarm set point

Notes:

- 1) EQ Mode will be initiated after the delay of 2 minutes upon acknowledging the set “Equalize Cycle” condition.
- 2) In any equalize mode, the ESCR will return to “FLOAT MODE” at the end of the equalize cycle.

2.4.5 Current Limit – Allows adjustment of the current limit from 50% to 110% of rated output.

1. Select LIMIT CURRENT from configuration menu
 - Select current limit as a percentage of the rated output current of the charger.

2.4.6 Temperature Compensation – Allows enable or disable of the temperature compensation feature.

1. Select TEMP. COMP. from configuration menu
 - Select DISABLE or ENABLE

NOTE: JP4 must be removed when temperature compensation is enabled.

2.4.7 Battery Test – Upon pressing and holding the “Lamp Test/Battery Test” button for 2 seconds, the charger will run the Battery test and “PERFORMING BATTERY TEST” will be displayed. The charger will lower the output voltage to check the battery voltage connected to the charger and generate a “BATTERY TEST PASSED” or “BATTERY FAILED PRESS RESET TO CLEAR” status after the test. The “BATT. FAULT” LED will illuminate once “BATTERY FAILED” is declared. Pressing the RESET button will clear the alarm, if present.

If the “BATTERY TEST PASSED” is displayed, the charger returns to default display (showing output voltage and current). This can be set to Automatic (Periodic Mode: Every day, every 7 days, or every 30 days) or can be done manually.

1. Select BATTERY TEST from configuration menu
 - Select MAN. BAT. TEST or AUTO BAT. TEST with the following selections available:

Every day: Battery Test is started automatically every day
7 Days: Battery Test is started automatically every 7 days
30 Days: Battery Test is started automatically every 30 days

2.4.8 Alarm Settings – Allows setting the alarm thresholds for the provided alarms and the alarm time delay

1. Select ALARM SETTING from the configuration menu.
 - In the ALARM SETTING menu select ALARM DELAY
 - Common Delay – Delay can be set from 1 second to 30 seconds.
 - High DC Shutdown – Delay can be set from 1 second to 255 seconds.
2. In the ALARM SETTING menu select DC LOW VOLTAGE
 - Select the desired low voltage alarm point in V/C (volts per cell)
3. In the ALARM SETTING menu select DC HIGH VOLTAGE
 - Select the desired high voltage alarm point in V/C (volts per cell)
4. In the ALARM SETTING menu select DC HI SHUTDOWN
 - Select the desired high DC shutdown alarm point in V/C (volts per cell)
5. In the ALARM SETTING menu select DC LOW CURRENT
 - Select the desired low DC current alarm point in amps
6. In the ALARM SETTING menu select AC FAIL VOLTAGE
 - Select the AC voltage operating range for the charger. Alarm will activate when the AC voltage is below the selected value

2.4.9 Factory Settings – Allows the user to reset all settings to how they were programmed from the factory. To reset the ESCR settings to the original factory settings, scroll to FACTORY SETTING in Configuration Mode. Select FACTORY SETTING. This will not change the BASIC OUTPUT settings.

2.4.10 Mains Voltage – This feature will read the AC voltage present at input terminals.

2.5 ESCR Customer Configuration Menu Structure

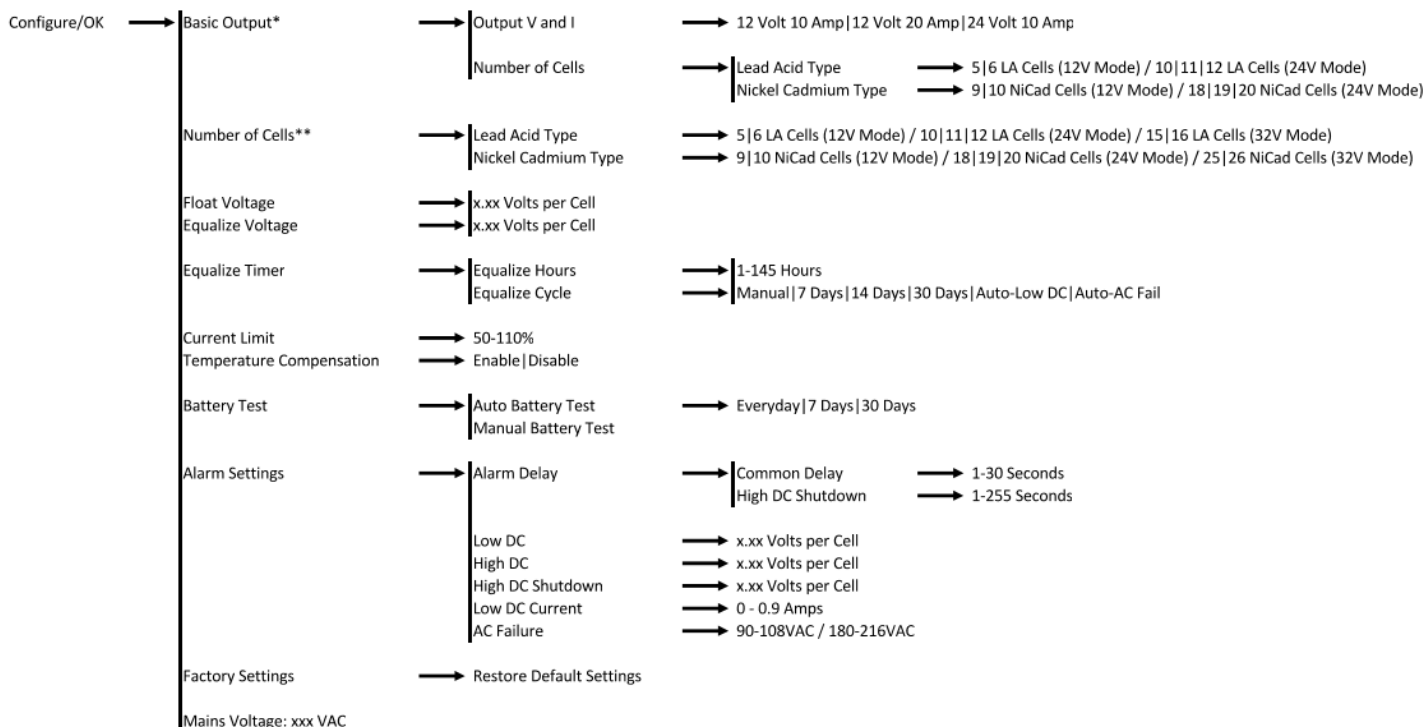

*Multi output chargers only
 **Single output chargers only

Menu structure subject to change without notice
 Revision: A00
 Revision Date: 05/19

3 Service

All work inside the ESCR should be performed by a qualified electrician. La Marche is not responsible for any damages caused by an unqualified technician.



Before working inside the ESCR ensure that the AC Power is off at the main breaker box. Disconnect the battery from the charger via the battery disconnect breaker or manually disconnecting the battery cables. Verify that no voltage is present by using a voltmeter at all input and output terminals.

3.1 Performing Routine Maintenance

Although very little maintenance is required on the ESCR V2 charger, routine checks and adjustments are recommended to ensure optimum system performance.

Yearly

1. Confirm air vents are open. Remove dust and debris from interior of charger.
2. Verify all connections are tight.
3. Check front panel display for accuracy and LED operation
4. Check capacitors for electrolyte leakage.

Every 7 Years (If the charger is consistently run in environments with extreme temperatures)

1. If the charger is consistently operated in higher temperature environments, filter capacitors are recommended to be replaced.

Every 10 Years

1. Replace capacitors if not done at the 7-year interval.
2. Check magnetics, components, and wiring for signs of excessive heat.

3.2 Troubleshooting Procedure

Troubleshooting should be performed only by trained service personnel or experienced electricians. Before setting up any complicated testing, give the unit a general inspection.

Check the following:

1. Check DC output cables, connections, battery type, and number of cells against the unit's rating.
2. Check unit specifications against customer order.
3. Check input connections, input voltage and feeder breaker/fuse.
4. Check any internal wiring, fuses, and breakers.
5. Check for shipping damage, loose connections, broken wires, etc.
6. Certain failures can be caused by defective batteries; make sure batteries are free from defects.

When calling in for a service inquiry or for troubleshooting assistance, be sure to have all of the following information on hand:

1. Equipment model number and serial number.
2. The measured AC input voltage.
3. The measured DC output voltage with and without the battery.
4. Result of the check of the AC and DC fuses/ breakers.
5. The measured DC output current and voltage, measured with battery and load connected to charger.

NOTE: *When ordering replacement parts, drawings, or schematics, always give model number and serial number.*

3.3 Troubleshooting Chart

Symptom	Possible Cause
AC Fuse Open (High Input Current)	Wrong AC Input Voltage Frequency Out of Range Internal Wiring Failure Defective Component on Rectifier Assembly
DC Fuse Open (High Output Current)	Internal Wiring Failure Incorrect Battery Connected Shorted Output Cables Battery Cable Polarity Reversed Defective Component on Rectifier Assembly
No Display and No LEDs	Internal Wiring Failure Defective Display Driver Board (S2A-348) Defective Control Board (S2A-349 / S2A-357)
Failed LED Test	Defective LEDs Defective Display Driver Board (S2A-348)
Meter Reading Incorrect Voltage or Current	Internal Wiring Failure Defective Shunt Defective Control Board (S2A-349 / S2A-357) Potentiometer Mis-adjustment
Unit Running Hot	Inadequate Ventilation Ambient is Too Hot
Battery Temperature Too High	Ambient is Too Hot Shorted Battery Cell(s) Float/Equalize Voltage Set Too High
Low Output Voltage or Current	Float/Equalize Voltage Incorrectly Set Charger is in Current Limit Open DC Fuse Defective Control Board (S2A-349 / S2A-357) Defective Component on Heatsink Assembly
High Output Voltage or Current	Float/Equalize Voltage Incorrectly Set Defective Control Board (S2A-349 / S2A-357) Defective Component on Heatsink Assembly Faulty Filter Capacitors

Appendix A: ESCR Specifications

<i>ELECTRICAL</i>	
AC Input	Auto Select 120/208-240 VAC $\pm 10\%$ / 120 VAC $\pm 10\%$ Frequency Range 50/60Hz
DC Output	10, 20, 40 ADC @ 12, 24 VDC / 10, 20 ADC @ 32 VDC
Output Filtering	Less than 500mV RMS, with connected battery
Regulation	$\pm 0.5\%$ from no load to full load over the specified input voltage, frequency and ambient temperature range.
Meters	LCD Digital Display DC Ammeter & DC Voltmeter $\pm 1\%$ Accuracy
<i>PROTECTION</i>	
Current Walk-In	The output current will gradually increase after the charger is turned on, eliminating surges and overshoot
Current Limit	50 - 110% of the rated DC output current.
AC Fuse	AC Fuse is standard.
DC Fuse	DC Fuse is standard.
<i>ENVIRONMENTAL</i>	
Operating Temperature	-20 to 50°C (-4 to 122°F), derated to 55°C
Storage Temperature	-40 to 85°C (-40 to 185°F)
Relative Humidity	5% to 95% (non-condensing)
Cooling	Convection cooled
Shock	The battery charger in its shipping container withstands shock developed when one edge of the container is dropped six inches while the opposite edge is resting on the ground, or it is dropped two inches without any physical damage or degradation of the electrical performance.
Vibration	The battery charger in its shipping contained, withstands vibration encountered in shipping without physical damage or degradation of the electrical performance.
Altitude	This battery charger is capable of operation at altitudes up to 10,000 feet at an ambient temperature of up to +40°C.

<i>ELECTRICAL</i>	
AC Input	120 Vac \pm 10% Frequency Range 50/60Hz
DC Output	20 ADC @ 32 VDC
Output Filtering	Less then 500mV RMS, with connected battery
Regulation	\pm 0.5% from no load to full load over the specified input voltage, frequency and ambient temperature range.
Meters	LCD Digital Display DC Ammeter & DC Voltmeter \pm 1% Accuracy
<i>PROTECTION</i>	
Current Walk-In	The output current will gradually increase after the charger is turned on, eliminating surges and overshoot
Current Limit	50 - 110% of the rated DC output current.
AC Fuse	AC Fuse is standard.
DC Fuse	DC Fuse is standard.
<i>ENVIROMENTAL</i>	
Operating Temperature	-20 to 50°C (-4 to 122°F), derated to 55°C
Storage Temperature	-40 to 85° C (-40 to 185° F)
Relative Humidity	5% to 95% (non-condensing)
Cooling	Convection cooled
Shock	The battery charger in its shipping container withstands shock developed when one edge of the container is dropped six inches while the opposite edge is resting on the ground, or it is dropped two inches without any physical damage or degradation of the electrical performance.
Vibration	The battery charger in its shipping contained, withstands vibration encountered in shipping without physical damage or degradation of the electrical performance.
Altitude	This battery charger is capable of operation at altitudes up to 10,000 feet at an ambient temperature of up to +40° C.

Appendix B: Manufacturer's Warranty

All La Marche Manufacturing Co. equipment has been thoroughly tested and found to be in proper operating condition upon shipment from the factory and is warranted to be free from any defect in workmanship and material that may develop within three (3) years from date of purchase.

Any part or parts of the equipment (except fuses, connectors and other wear-related items) that prove defective within a three (3) year period shall be replaced without charge providing such defect, in our opinion, is due to faulty material or workmanship and not caused by tampering, abuse, misapplication or improper installation.

Should a piece of equipment require repair during the warranty period, the equipment can be returned to the La Marche factory to have the inspection, parts replacements and testing performed by factory personnel. Should it be necessary to return a piece of equipment or parts to the factory, the customer or sales representative must obtain authorization from the factory. If upon inspection at the factory, the defect was due to faulty material or workmanship, all repairs will be made at no cost to the customer during the first three years. Transportation charges or duties shall be borne by purchaser.

In accepting delivery of the equipment, the purchaser assumes full responsibility for proper installation, installation adjustments and service arrangements. Should minor adjustments be required, the local La Marche sales representative should be contacted to provide this service only.

All sales are final. Only standard La Marche units will be considered for return. A 25% restocking fee is charged when return is factory authorized. Special units are not returnable.

In no event shall La Marche Manufacturing Co. have any liability for consequential damages, or loss, damage or expense directly or indirectly arising from the use of the products, or any inability to use them either separately or in combination with other equipment or materials, or from any other cause. In addition, any alterations of equipment made by anyone other than La Marche Manufacturing Co. renders this warranty null and void.

La Marche Manufacturing Co. reserves the right to make revisions in current production of equipment, and assumes no obligation to incorporate these revisions in earlier models.

The failure of La Marche Manufacturing Co. to object to provisions contained in customers' purchase orders or other communications shall not be deemed a waiver of the terms or conditions hereof, nor acceptance of such provisions.

The above warranty is exclusive, supersedes and is in lieu of all other warranties, expressed or implied, including any implied warranty of merchantability or fitness. No person, agent or dealer is authorized to give any warranties on behalf of the Manufacturer, nor to assume for the Manufacturer any other liability in connection with any of its products unless made in writing and signed by an official of the manufacturer.

Appendix C: Document Control and Revision History

Part Number: 141776
Instruction Number: P25-LESCR-V2-1
Issue ECN: **22384 – 11/19**

22552 – 05/20	23251 08/22		